

A BDDC ALGORITHM FOR PROBLEMS WITH MORTAR DISCRETIZATION *

HYEA HYUN KIM [†], MAKSYMILIAN DRYJA [‡], AND OLOF B. WIDLUND [§]

September 22, 2005

Abstract. A BDDC (balancing domain decomposition by constraints) algorithm is developed for elliptic problems with mortar discretizations for geometrically non-conforming partitions in both two and three spatial dimensions. The coarse component of the preconditioner is defined in terms of one mortar constraint for each edge/face which is an intersection of the boundaries of a pair of subdomains. A condition number bound of the form $C \max_i \{(1 + \log(H_i/h_i))^3\}$ is established. In geometrically conforming cases, the bound can be improved to $C \max_i \{(1 + \log(H_i/h_i))^2\}$. This estimate is also valid in the geometrically nonconforming case under an additional assumption on the ratio of mesh sizes and jumps of the coefficients. This BDDC preconditioner is also shown to be closely related to the Neumann-Dirichlet preconditioner for the FETI-DP algorithms of [9, 11] and it is shown that the eigenvalues of the BDDC and FETI-DP methods are the same except possibly for an eigenvalue equal to 1.

Key words. BDDC, FETI-DP, mortar methods, preconditioner

AMS subject classifications. 65N30, 65N55

1. Introduction. This study focuses on a scalable BDDC algorithm for solving linear systems arising from mortar finite element discretizations of elliptic problems. A BDDC method was first introduced by Dohrmann [4] as an improvement of the balancing Neumann-Neumann method and using different coarse finite element spaces. The coarse space consists of a weighted sum of functions each of which minimizes the local discrete energy norm with certain constraints on the subdomain interfaces; continuity of the solutions at vertices, or average or momentum matching condition on solutions over edges/faces are considered in [4, 16, 17, 19, 20]. The resulting coarse problem then gives a more local coupling between the subdomains than for the older balancing methods and more freedom in choosing the constraints to improve the convergence. An additional advantage is that all linear systems will have positive definite, symmetric matrices at least for conforming finite element problems.

The constraints on the coarse finite element space are basically the same as those of a

*The first author was supported in part by the Applied Mathematical Sciences Program of the U.S. Department of Energy under contract DE-FG02-00ER25053 and in part by the Post-doctoral Fellowship Program of Korea Science and Engineering Foundation (KOSEF). The second author was supported in part by Polish Sciences Foundation under grant 2P03A00524. The third author was supported in part by the U.S. Department of Energy under contract DE-FC02-01ER25482.

[†]Division of Applied Mathematics, KAIST, Gusong-Dong 373-1, Yusong-Gu, Daejeon, 305-701. Republic of Korea. Electronic mail address: mashy@amath.kaist.ac.kr.

[‡]Department of Mathematics, Warsaw University, Banach 2, 02-097 Warsaw, Poland. Electronic mail address: dryja@mimuw.edu.pl.

[§]Courant Institute of Mathematical Sciences, 251 Mercer Street, New York, N.Y. 10012. U.S.A. Electronic mail address: widlund@cs.nyu.edu. URL: <http://cs.nyu.edu/cs/faculty/widlund/index.html>.

FETI–DP algorithm. In a FETI–DP algorithm, a linear system formulated for a set of dual variables is solved after eliminating the primal unknowns related to the primal constraints, given by average matching condition over edges/faces or continuity of the solutions at vertices. The resulting linear system, in itself, contains a coarse problem while its preconditioner is built only from subdomain problems. In a BDDC method, a linear system of the primal variables is solved iteratively with a preconditioner that has both coarse and subdomain components. This provides BDDC methods with more flexibility, allowing for the use of inexact coarse problems. Thus, an inexact coarse problem can be introduced by applying the BDDC method recursively to the coarse problem; see Tu [22, 23]. The use of inexact local problems for the BDDC preconditioners has also been considered by Li and Widlund [18].

Recently the BDDC methods have been shown to be closely related to the FETI–DP methods. A condition number bound of the BDDC operator was first given by Mandel and Dohrmann [19]. They proved a $C(1 + \log(H/h))^2$ bound that is comparable to that for the FETI–DP methods. Further, Mandel, Dohrmann, and Tezaur [20] showed that the eigenvalues of the FETI–DP and BDDC operators are the same except possibly for eigenvalues equal to 0 and 1. Recently, a new formulation of the BDDC method was given by Li and Widlund [17]. They introduced a change of variables as well as an average operator for the BDDC method based on the jump operator used in [15] in the analysis of FETI–DP methods. The change of variables greatly simplifies the analysis; it has also led to a successful and robust implementation of FETI–DP algorithms [12, 13].

In this paper, we will first describe a BDDC algorithm with a mortar discretization and a change of variables. Primal constraints on edges/faces are introduced. We consider quite general geometrically non-conforming partitions and the second generation of the mortar method as well as the dual basis mortar methods. A preconditioner is then proposed which uses a certain weight matrix D , that leads to the condition number bound: $C \max_i \{(1 + \log(H_i/h_i))^3\}$. Section 4 is devoted to proving the condition number bound in terms of a bound of an average operator E_D in a certain norm. The algorithm can also be applied to a geometrically conforming partition and then gives a better bound: $C \max_i \{(1 + \log(H_i/h_i))^2\}$. The same bound can be established for geometrically non-conforming partitions with an additional assumption on the mesh sizes.

In Section 5, we show that the preconditioner proposed for our BDDC algorithm is closely connected to the Neumann-Dirichlet preconditioner of the FETI–DP algorithm given in [9, 11]. By establishing connections between the average and jump operators, the spectra of the BDDC and FETI–DP algorithms are then shown to be the same except possibly for an eigenvalue equal to 1. This approach was used by Li and Widlund [17] and provided a simpler proof for the condition number bound of the BDDC algorithm. Our BDDC algorithm is also applicable to elasticity problems employing a preconditioner that is closely connected to the Neumann-Dirichlet preconditioner of the FETI–DP formulation developed in [10].

In the final section, numerical results show that the FETI–DP and BDDC algorithms perform very similarly when the same set of primal constraints are selected.

Throughout this paper, C denotes a generic constant that does not depend on any mesh parameters and coefficients of the elliptic problems.

We note that this paper originated from two projects developed separately by the first and the second authors; the contribution of the third author began with a suggestion that a theory could be developed for the geometrically non-conforming case.

2. Finite element spaces and mortar matching constraints.

2.1. A model problem and mortar methods. We consider a model elliptic problem in a polygonal/polyhedral domain $\Omega \subset \mathbb{R}^2$ (\mathbb{R}^3): find $u \in H_0^1(\Omega)$ such that

$$(2.1) \quad \begin{aligned} -\nabla \cdot (\rho(x)\nabla u) &= f(x) \quad \forall x \in \Omega, \\ u &= 0 \quad \text{on } \partial\Omega, \end{aligned}$$

where $\rho(x) \geq \rho_0 > 0$ and $f(x) \in L^2(\Omega)$.

Let Ω be partitioned into disjoint polygonal/polyhedral subdomains

$$\bar{\Omega} = \bigcup_{i=1}^N \bar{\Omega}_i.$$

We assume that the partition can be geometrically non-conforming, see discussion below, and that $\rho(x) = \rho_i$, $x \in \Omega_i$ for some positive constant ρ_i .

We denote by X_i the P_1 -conforming finite element space on a quasi-uniform triangulation T_i of each subdomain Ω_i . The T_i might not align across subdomain interfaces. The space W_i is the trace space of X_i on $\partial\Omega_i$. We then introduce the product spaces

$$X := \prod_{i=1}^N X_i, \quad W := \prod_{i=1}^N W_i.$$

For functions in these spaces, we will impose the mortar matching condition across the interfaces using suitable Lagrange multiplier spaces.

In a geometrically non-conforming partition, the intersection of the boundaries of neighboring subdomains can be only a part of an edge/face of a subdomain. Let us define the entire interface by

$$\Gamma = \left(\bigcup_{ij} \partial\Omega_i \cap \partial\Omega_j \right) \setminus \partial\Omega.$$

Among the subdomain edges/faces, we select nonmortar edges/faces F_l for which

$$\bigcup_l \bar{F}_l = \bar{\Gamma}, \quad F_l \cap F_k = \emptyset, \quad l \neq k.$$

Since the subdomain partition can be geometrically non-conforming, a single nonmortar edge/face $F_l \subset \partial\Omega_i$ may intersect several subdomain boundaries $\partial\Omega_j$. This provides F_l with a partition

$$\bar{F}_l = \bigcup_j \bar{F}_{ij}, \quad F_{ij} = \partial\Omega_i \cap \partial\Omega_j.$$

A dual or a standard Lagrange multiplier space M_l is given for each nonmortar edge/face F_l . We require that the space M_l has the same dimension as the space $\mathring{W}(F_l) := W_i|_{F_l} \cap H_0^1(F_l)$ and that it contains the constant functions. Constructions of such Lagrange multiplier spaces were introduced in [1, 3] for standard Lagrange multiplier spaces and in [24, 25] for dual Lagrange multiplier spaces; see also [8].

For $(w_1, \dots, w_N) \in W$, we define $\phi \in L^2(F_l)$ by $\phi = w_j$ on $F_{ij} \subset F_l$. The mortar matching condition for the geometrically non-conforming partition is given by

$$(2.2) \quad \int_{F_l} (w_i - \phi)\lambda \, ds = 0, \quad \forall \lambda \in M_l, \forall F_l.$$

We write its matrix representation as

$$(2.3) \quad \sum_{i=1}^N B^{(i)} w^{(i)} = 0,$$

with $w^{(i)}$ a vector representation of w_i using nodal basis functions. We further define the following product spaces by gathering the spaces M_l and $\mathring{W}(F_l)$ given on each nonmortar edges/faces:

$$(2.4) \quad M = \prod M_l, \quad W_n = \prod \mathring{W}(F_l).$$

The mortar finite element method for problem (2.1) is to approximate the solution by Galerkin's method in the mortar finite element space

$$\hat{X} := \{v \in X : v \text{ satisfies the mortar matching condition (2.2)}\}.$$

2.2. Finite element spaces with a change of variables. In this subsection, we introduce a change of variables for the unknowns in the space W . This change of variables is based on the primal constraints that will be imposed in our BDDC algorithm. In mortar discretizations, we may consider the following sets of primal constraints; vertex constraints, vertex and edge average constraints, or edge average constraints only for two spatial dimensions, and vertex constraints and face average constraints, or face average constraints only for three spatial dimensions. We note that vertex constraints are appropriate only for the first generation of the mortar method. In order to reduce the number of primal constraints, we can select only some edges/faces or some vertices as primal where the primal constraints will be imposed. Such choices have been considered for the FETI-DP algorithms and conforming finite elements in [14] and for mortar finite elements in [10].

In our BDDC formulation, we will introduce certain primal constraints over edges/faces that are selected from the mortar matching constraints (2.2). We consider $\{\psi_{ij,k}\}_k$, the basis functions in M_l that are supported in \overline{F}_{ij} , and define

$$\psi_{ij} = \sum_k \psi_{ij,k}.$$

We assume that at least one such basis function $\psi_{ij,k}$ exists for each $F_{ij} \subset F_l$.

We now introduce the following primal constraints for $(w_1, \dots, w_N) \in W$ over each edge/face F_{ij}

$$(2.5) \quad \int_{F_{ij}} (w_i - w_j) \psi_{ij} ds = 0,$$

and define

$$(2.6) \quad \widetilde{W} = \{w \in W : w \text{ satisfies the primal constraints (2.5)}\}.$$

Note that $\widehat{W} \subset \widetilde{W} \subset W$, where \widehat{W} is the restriction of \widehat{X} to Γ . For the case of a geometrically conforming partition, i.e., when F_{ij} is a full face of two subdomains, the above constraints are edge/face average matching condition because $\psi_{ij} = 1$. In addition to the above constraints, vertex constraints can be considered for the first generation mortars if the partition is geometrically conforming.

We now introduce a change of variables, following Li and Widlund [17], based on the primal constraints and in the two dimensional case. This approach can also be extended to the three dimensional case without any difficulty.

We recall that $F \subset \partial\Omega_i$ is a nonmortar edge/face and that $\{F_{ij}\}_j$ is a partition of F given by $F_{ij} = F \cap \partial\Omega_j$, a mortar edge/face of Ω_j . We denote by $\{z_k\}_{k=1}^l$ the unknowns of $w_i \in W_i$ at the nodes in F related to the Lagrange multipliers $\{\psi_{ij,k}\}$ and by $\{v_k\}_{k=1}^p$ the unknowns at the remaining nodes in \overline{F} . We will now define a transform that retains the unknowns $\{v_k\}_{k=1}^p$ and changes $\{z_k\}_{k=1}^l$ into $\{\widehat{z}_k\}_{k=1}^l$ so that for a fixed m , chosen arbitrarily, \widehat{z}_m satisfies

$$\widehat{z}_m = \frac{\int_{F_{ij}} w_i \psi_{ij} ds}{\int_{F_{ij}} \psi_{ij} ds}.$$

Let

$$\widetilde{h}_k = \frac{\int_{F_{ij}} \widetilde{\phi}_k \psi_{ij} ds}{\int_{F_{ij}} \psi_{ij} ds}, \quad h_k = \frac{\int_{F_{ij}} \phi_k \psi_{ij} ds}{\int_{F_{ij}} \psi_{ij} ds},$$

where $\widetilde{\phi}_k$ and ϕ_k are the nodal basis functions of the unknowns v_k and z_k , respectively. For a simpler presentation, we assume that $p = 2$ but the following can be generalized to any p .

We then consider the following transform $T_{F_{ij}}$:

$$\begin{aligned}
\begin{pmatrix} v_1 \\ v_2 \\ z_1 \\ \vdots \\ z_{m-1} \\ z_m \\ z_{m+1} \\ \vdots \\ z_l \end{pmatrix} &= T_{F_{ij}} \begin{pmatrix} v_1 \\ v_2 \\ \widehat{z}_1 \\ \vdots \\ \widehat{z}_{m-1} \\ \widehat{z}_m \\ \widehat{z}_{m+1} \\ \vdots \\ \widehat{z}_l \end{pmatrix} = \begin{pmatrix} 1 & 0 & 0 & \cdots & 0 & 0 & 0 & \cdots & 0 \\ 0 & 1 & 0 & \cdots & 0 & 0 & 0 & \cdots & 0 \\ 0 & 0 & 1 & \cdots & 0 & A & 0 & \cdots & 0 \\ \vdots & \vdots & \vdots & \ddots & \vdots & \vdots & \vdots & \ddots & \vdots \\ 0 & 0 & 0 & \cdots & 1 & A & 0 & \cdots & 0 \\ c_1 & c_2 & r_1 & \cdots & r_{m-1} & A & r_{m+1} & \cdots & r_l \\ 0 & 0 & 0 & \cdots & 0 & A & 1 & \cdots & 0 \\ \vdots & \vdots & \vdots & \ddots & \vdots & \vdots & \vdots & \ddots & \vdots \\ 0 & 0 & 0 & \cdots & 0 & A & 0 & \cdots & 1 \end{pmatrix} \begin{pmatrix} v_1 \\ v_2 \\ \widehat{z}_1 \\ \vdots \\ \widehat{z}_{m-1} \\ \widehat{z}_m \\ \widehat{z}_{m+1} \\ \vdots \\ \widehat{z}_l \end{pmatrix} \\
&= A \begin{pmatrix} 0 \\ 0 \\ 1 \\ \vdots \\ \vdots \\ \widehat{z}_m + \\ \vdots \\ \vdots \\ \vdots \\ \vdots \\ 1 \end{pmatrix} + \begin{pmatrix} v_1 \\ v_2 \\ \widehat{z}_1 \\ \vdots \\ \widehat{z}_{m-1} \\ \widehat{z}_0 \\ \widehat{z}_{m+1} \\ \vdots \\ \vdots \\ \vdots \\ \widehat{z}_l \end{pmatrix},
\end{aligned}$$

where

$$\widehat{z}_0 = c_1 v_1 + c_2 v_2 + r_1 \widehat{z}_1 + \cdots + r_{m-1} \widehat{z}_{m-1} + r_{m+1} \widehat{z}_{m+1} + \cdots + r_l \widehat{z}_l,$$

$$A = \frac{\int_{F_{ij}} \psi_{ij} ds}{\sum_{k=1}^l h_k}, \quad c_1 = -\frac{\widetilde{h}_1}{h_m}, \quad c_2 = -\frac{\widetilde{h}_2}{h_m}, \quad r_k = -\frac{h_k}{h_m}, \quad k \neq m.$$

We see that this transform satisfies the requirements stated above. The transform $T_{F_{ij}}$ can be applied to each face $F_{ij} \subset F$ independently.

For the case when an edge $F \subset \partial\Omega_i$ is a mortar edge, there exists a Ω_j across the interface with a nonmortar side. We then consider $F_{ij} = F \cap \partial\Omega_j$. In this case, the unknowns $\{z_k\}_{k=1}^l$ are related to the nodes in F with its basis functions supported in \overline{F}_{ij} and the remaining unknowns in F are denoted by $\{v_k\}_{k=1}^p$. The transform $T_{F_{ij}}$ is then defined for these unknowns as before.

By gathering the transforms $T_{F_{ij}}$ of all $F \subset \partial\Omega_i$, we get a transform $T^{(i)} : \widehat{W}_i \rightarrow W_i$ of the form

$$T^{(i)} = \begin{pmatrix} T_{rr}^{(i)} & T_{rc}^{(i)} \\ 0 & I \end{pmatrix},$$

where c and r stand for the unknowns retained by the transform and the remaining unknowns, respectively, and \widehat{W}_i denotes the space of new unknowns. With this set of new unknowns, the local stiffness matrix, the mortar matching matrix, and the local force vector are written as

$$\widehat{S}^{(i)} = T^{(i)t} S^{(i)} T^{(i)}, \quad \widehat{B}^{(i)} = B^{(i)} T^{(i)}, \quad \widehat{g}^{(i)} = T^{(i)t} g^{(i)}.$$

The unknowns \widehat{z}_m , the unknowns for the averages over the edges, are the primal variables. With this set of new variables, the space \widetilde{W} in (2.6) can be represented as

$$(2.7) \quad \widetilde{W} = W_\Delta \oplus W_\Pi,$$

where W_Δ consists of functions with a zero value at the primal variables and W_Π consists of functions with a zero value at the other variables. We denote by $R_\Pi^{(i)}$ the restriction of the primal unknowns $u_\Pi \in W_\Pi$ to the subdomain Ω_i . By using the set of new unknowns, the mortar matching condition (2.3) can be written as

$$(2.8) \quad B_\Delta w_\Delta + B_\Pi w_\Pi = 0.$$

Here

$$B_\Delta = \left(B_\Delta^{(1)} \cdots B_\Delta^{(N)} \right), \quad B_\Pi = \sum_{i=1}^N B_\Pi^{(i)} R_\Pi^{(i)},$$

where $B_\Pi^{(i)}$ and $B_\Delta^{(i)}$ are submatrices of $\widehat{B}^{(i)}$ with columns corresponding to the primal variables and the remaining unknowns, respectively.

Furthermore the mortar matching condition on functions in \widetilde{W} will be imposed by using non-redundant Lagrange multipliers. We select the non-redundant Lagrange multipliers as follows. From the bases of M_l , we eliminate one basis element among $\{\psi_{ij,k}\}_k$ for each $F_{ij} \subset F_l$ and denote the reduced Lagrange multiplier space by \overline{M}_l . The non-redundant Lagrange multiplier space is then defined as

$$\overline{M} = \prod_l \overline{M}_l.$$

The mortar matching condition (2.2) is imposed on the space \widetilde{W} by using the non-redundant Lagrange multipliers $\lambda \in \overline{M}$. To simplify the notation, we use the same notation as in (2.8) for this case, i.e.,

$$B_\Delta w_\Delta + B_\Pi w_\Pi = 0.$$

The space W_Δ can be split into

$$W_\Delta = W_{\Delta,n} \oplus W_{\Delta,m},$$

where n and m denote unknowns at nonmortar edges/faces (interior) and the remaining unknowns, respectively. The above equation can be written as

$$(2.9) \quad B_n w_n + B_m w_m + B_\Pi w_\Pi = 0.$$

After the change of variables, we order the local Schur complement matrix and the local Schur complement vector into

$$\widehat{S}^{(i)} = \begin{pmatrix} \widehat{S}_{\Delta\Delta}^{(i)} & \widehat{S}_{\Delta\Pi}^{(i)} \\ \widehat{S}_{\Pi\Delta}^{(i)} & \widehat{S}_{\Pi\Pi}^{(i)} \end{pmatrix}, \quad \widehat{g}^{(i)} = \begin{pmatrix} \widehat{g}_\Delta^{(i)} \\ \widehat{g}_\Pi^{(i)} \end{pmatrix}$$

and define a matrix and vectors by

$$(2.10) \quad \widetilde{S} = \begin{pmatrix} S_{\Delta\Delta} & S_{\Delta\Pi} \\ S_{\Pi\Delta} & S_{\Pi\Pi} \end{pmatrix}, \quad g_\Delta = \begin{pmatrix} \widehat{g}_\Delta^{(1)} \\ \vdots \\ \widehat{g}_\Delta^{(N)} \end{pmatrix}, \quad g_\Pi = \sum_{i=1}^N R_\Pi^{(i)t} \widehat{g}_\Pi^{(i)},$$

where

$$(2.11) \quad \begin{aligned} S_{\Delta\Delta} &= \text{diag}_{i=1}^N \left(\widehat{S}_{\Delta\Delta}^{(i)} \right), \\ S_{\Pi\Delta} &= \left(R_\Pi^{(1)t} \widehat{S}_{\Pi\Delta}^{(1)} \quad \dots \quad R_\Pi^{(N)t} \widehat{S}_{\Pi\Delta}^{(N)} \right), \quad S_{\Delta\Pi} = S_{\Pi\Delta}^t, \\ S_{\Pi\Pi} &= \sum_{i=1}^N R_\Pi^{(i)t} \widehat{S}_{\Pi\Pi}^{(i)} R_\Pi^{(i)}. \end{aligned}$$

3. A BDDC algorithm for the mortar discretizations. In this section, we formulate a BDDC operator for the elliptic problem described in Section 2.1. We consider the same finite element space and subdomain partition as in Section 2.1 and use the unknowns after the change of variables introduced in Section 2.2. We will omit the hats for the transformed matrices to simplify the notation.

We recall the mortar matching condition (2.9). Since the matrix B_n is invertible, we solve (2.9) for w_n

$$w_n = -B_n^{-1}(B_m w_m + B_\Pi w_\Pi).$$

We then define the matrix

$$(3.1) \quad R_\Gamma = \begin{pmatrix} -B_n^{-1}B_m & -B_n^{-1}B_\Pi \\ I & 0 \\ 0 & I \end{pmatrix},$$

which maps $(w_m^t, w_\Pi^t)^t$ into a vector $(w_n^t, w_m^t, w_\Pi^t)^t$ that satisfies the mortar matching condition (2.9). Let us define the mortar finite element space by

$$\widehat{W} = \left\{ w \in \widetilde{W} : (w_n, w_m, w_\Pi) \text{ satisfies (2.9)} \right\}.$$

In the BDDC method, we approximate the solution of the elliptic problem in the mortar finite element space \widehat{W} and obtain the following discrete problem:

$$(3.2) \quad R_\Gamma^t \widetilde{S} R_\Gamma \begin{pmatrix} w_m \\ w_\Pi \end{pmatrix} = R_\Gamma^t \begin{pmatrix} g_m \\ g_\Pi \end{pmatrix},$$

where g_m is the component of the vector g_Δ in (2.10) other than the nonmortar part.

We now introduce a coarse finite element space based on the primal constraints so as to solve (3.2) efficiently. In each subdomain, we solve the following problem

$$(3.3) \quad \begin{pmatrix} S_{\Delta\Delta}^{(i)} & S_{\Delta\Pi}^{(i)} \\ S_{\Pi\Delta}^{(i)} & S_{\Pi\Pi}^{(i)} \end{pmatrix} \begin{pmatrix} \Psi_\Delta^{(i)} \\ I_\Pi^{(i)} \end{pmatrix} = \begin{pmatrix} 0 \\ F_{\Pi\Pi}^{(i)} I_\Pi^{(i)} \end{pmatrix},$$

where the matrix $I_\Pi^{(i)}$ is the identity matrix of a dimension equal to the number of primal variables of Ω_i . We then obtain

$$\Psi^{(i)} = \begin{pmatrix} \Psi_\Delta^{(i)} \\ I_\Pi^{(i)} \end{pmatrix} = \begin{pmatrix} -(S_{\Delta\Delta}^{(i)})^{-1} S_{\Delta\Pi}^{(i)} I_\Pi^{(i)} \\ I_\Pi^{(i)} \end{pmatrix}$$

and also

$$F_{\Pi\Pi}^{(i)} = S_{\Pi\Pi}^{(i)} - S_{\Pi\Delta}^{(i)} S_{\Delta\Delta}^{(i)-1} S_{\Delta\Pi}^{(i)}.$$

Let $R_\Pi^{(i)} : W_\Pi \rightarrow W_\Pi^{(i)}$ restrict the global primal variables to the subdomain Ω_i . From $\Psi^{(i)}$, we construct the coarse finite element space Ψ as follows:

$$\Psi = \begin{pmatrix} \Psi^{(1)} R_\Pi^{(1)} \\ \vdots \\ \Psi^{(N)} R_\Pi^{(N)} \end{pmatrix}.$$

Each column ψ of the matrix Ψ is related to a primal variable. Since, the vector $\psi \in W$ has the same values at the primal variables, we take $\bar{\psi} = (\psi_\Delta^t, \psi_\Pi^t)^t$ from the vector ψ and define a matrix $\bar{\Psi}$ with the columns $\bar{\psi}$. We then obtain

$$(3.4) \quad \bar{\Psi} = R_\Pi^t - \sum_{i=1}^N (R_\Delta^{(i)})^t (S_{\Delta\Delta}^{(i)})^{-1} S_{\Delta\Pi}^{(i)} R_\Pi^{(i)},$$

where $R_\Pi^t : W_\Pi \rightarrow W_\Delta \times W_\Pi$ and $(R_\Delta^{(i)})^t : W_\Delta^{(i)} \rightarrow W_\Delta \times W_\Pi$ are zero extensions.

Let us now define

$$(3.5) \quad R_{D,\Gamma} = \begin{pmatrix} D_{nn} & & \\ & D_{mm} & \\ & & D_{\Pi\Pi} \end{pmatrix} R_\Gamma,$$

where the matrices D_{nn} , D_{mm} and D_{III} will be specified later. We then propose the following preconditioner M^{-1} for the problem (3.2)

$$(3.6) \quad M^{-1} = R_{D,\Gamma}^t \left\{ \begin{pmatrix} S_{\Delta\Delta}^{-1} & 0 \\ 0 & 0 \end{pmatrix} + \bar{\Psi}(\Psi^t S \Psi)^{-1} \bar{\Psi}^t \right\} R_{D,\Gamma},$$

where

$$S = \text{diag}_i \left(S^{(i)} \right)$$

and $S_{\Delta\Delta}$ is given in (2.11). We will show that

$$\Psi^t S \Psi = F_{\text{III}},$$

where

$$F_{\text{III}} = S_{\text{III}} - S_{\Pi\Delta} S_{\Delta\Delta}^{-1} S_{\Delta\Pi} = \sum_{i=1}^N (R_{\Pi}^{(i)})^t \left(S_{\text{III}}^{(i)} - S_{\Pi\Delta}^{(i)} (S_{\Delta\Delta}^{(i)})^{-1} S_{\Delta\Pi}^{(i)} \right) R_{\Pi}^{(i)}.$$

From the definition of Ψ , we have

$$\Psi^t S \Psi = \sum_{i=1}^N (R_{\Pi}^{(i)})^t (\Psi^{(i)})^t S^{(i)} \Psi^{(i)} R_{\Pi}^{(i)},$$

and from (3.3), we obtain

$$(3.7) \quad \Psi^t S \Psi = \sum_{i=1}^N (R_{\Pi}^{(i)})^t F_{\text{III}}^{(i)} R_{\Pi}^{(i)} = F_{\text{III}}.$$

Using the block Cholesky decomposition of \tilde{S} as in Li and Widlund [17] and above, see also (2.10), we have

$$\begin{aligned} \tilde{S}^{-1} &= \begin{pmatrix} S_{\Delta\Delta}^{-1} & 0 \\ 0 & 0 \end{pmatrix} \\ &+ \left(R_{\Pi}^t - \sum_{i=1}^N (R_{\Delta}^{(i)})^t (S_{\Delta\Delta}^{(i)})^{-1} S_{\Delta\Pi}^{(i)} R_{\Pi}^{(i)} \right) F_{\text{III}}^{-1} \\ &\quad \left(R_{\Pi}^t - \sum_{i=1}^N (R_{\Delta}^{(i)})^t (S_{\Delta\Delta}^{(i)})^{-1} S_{\Delta\Pi}^{(i)} R_{\Pi}^{(i)} \right)^t. \end{aligned}$$

By combining the above equation with (3.4) and (3.7), we obtain

$$\tilde{S}^{-1} = \begin{pmatrix} S_{\Delta\Delta}^{-1} & 0 \\ 0 & 0 \end{pmatrix} + \bar{\Psi}(\Psi^t S \Psi)^{-1} \bar{\Psi}^t.$$

Therefore, the BDDC operator, see (3.2), with the preconditioner M^{-1} in (3.6) can be written as

$$(3.8) \quad B_{DDC} = R_{D,\Gamma}^t \tilde{S}^{-1} R_{D,\Gamma} R_{\Gamma}^t \tilde{S} R_{\Gamma}.$$

4. Condition number analysis using a bound on E_D . In this section, we will estimate the condition number of the BDDC operator by using an approach introduced in [16]. A bound for the average operator E_D in a certain norm is central in the analysis. We recall the definitions of R_Γ and $R_{D,\Gamma}$ in (3.1) and (3.5), respectively. The operator E_D is defined as

$$(4.1) \quad E_D = R_\Gamma R_{D,\Gamma}^t,$$

where the weight matrix D will be chosen so that

$$(P1) \quad R_\Gamma^t R_{D,\Gamma} = R_{D,\Gamma}^t R_\Gamma = I$$

$$(P2) \quad |E_D w|_{\tilde{S}}^2 \leq C \max_i \left\{ \left(1 + \log \frac{H_i}{h_i} \right)^3 \right\} |w|_{\tilde{S}}^2.$$

Here $|w|_{\tilde{S}}^2 = \langle \tilde{S} w, w \rangle$. We then have

$$R_\Gamma^t R_{D,\Gamma} \begin{pmatrix} w_m \\ w_\Pi \end{pmatrix} = \begin{pmatrix} -B_m^t (B_n^t)^{-1} D_{nn} z_n + D_{mm} w_m \\ -B_\Pi^t (B_n^t)^{-1} D_{nn} z_n + D_{\Pi\Pi} w_\Pi \end{pmatrix},$$

where

$$z_n = -B_n^{-1} (B_m w_m + B_\Pi w_\Pi).$$

In order to satisfy property (P1), the weight matrix D is chosen so that

$$(4.2) \quad D_{nn} = 0, \quad D_{mm} = I, \quad D_{\Pi\Pi} = I.$$

REMARK 4.1. *The weights above lead to an operator E_D of the form*

$$E_D \begin{pmatrix} w_n \\ w_m \\ w_\Pi \end{pmatrix} = \begin{pmatrix} -B_n^{-1} (B_m w_m + B_\Pi w_\Pi) \\ w_m \\ w_\Pi \end{pmatrix}$$

that does not involve any averages across the interfaces in contrast to the average operator considered for conforming finite elements. We will still call E_D the average operator just borrowing the name from the conforming case.

We will now show that the average operator E_D satisfies property (P2) with the weight matrix D just given. As a preparation, we need to establish an estimate for the mortar projection of a function w in \tilde{W} in the $H_{00}^{1/2}(F)$ -norm. For an edge/face $F \subset \partial\Omega_i$, the space $H_{00}^{1/2}(F)$ consists of functions for which the zero extension to the whole boundary $\partial\Omega_i$ belongs to the Sobolev space $H^{1/2}(\partial\Omega_i)$. It is equipped with the norm

$$\|w\|_{H_{00}^{1/2}(F)}^2 = |w|_{H^{1/2}(F)}^2 + \int_F \frac{w(x)^2}{\text{dist}(x, \partial F)} ds(x).$$

This norm has the well-known property

$$(4.3) \quad c|\tilde{w}|_{H^{1/2}(\partial\Omega_i)} \leq \|w\|_{H_{00}^{1/2}(F)} \leq C|\tilde{w}|_{H^{1/2}(\partial\Omega_i)},$$

where \tilde{w} is the zero extension of w to $\partial\Omega_i \setminus F$; see [7, Lemma 1.3.2.6].

We recall that the subdomain Ω_j intersect the subdomain Ω_i along $F_{ij} \subset F$ where F is a nonmortar edge/face in $\partial\Omega_i$ and that $\phi = w_j$ on F_{ij} . We then have $\phi \in H^{1/2-\epsilon}(F)$, $0 < \epsilon \leq 1/2$ and the following estimate; see Proposition 3.2 in [2].

LEMMA 4.2. *Assume that Ω_i and Ω_j are scaled by the diameter H_i of the Ω_i . For $\phi \in H^{1/2-\epsilon}(F)$ and $0 < \epsilon \leq 1/2$, we have*

$$\epsilon \|\phi\|_{H^{1/2-\epsilon}(F)}^2 \leq C \sum_j \|w_j\|_{1/2, \partial\Omega_j}^2.$$

We need the following assumption on the coefficients of the elliptic problem.

ASSUMPTION 4.3. *The coefficients satisfy*

$$\rho_i \leq C \rho_j$$

where Ω_i and Ω_j are the nonmortar side and the mortar side of the common set $F_{ij} = \partial\Omega_i \cap \partial\Omega_j$.

For any set $A \subset \partial\Omega_i$ and $w_i \in W_i$, we define a nodal value interpolant $I_A(w_i) \in W_i$ as

$$(4.4) \quad I_A(w_i)(x) = \begin{cases} w_i(x) & x \in A \cap \mathcal{V}_i, \\ 0 & \text{at the other nodes.} \end{cases}$$

Here \mathcal{V}_i denotes the set of nodes in the finite element space W_i . Let $F \subset \partial\Omega_i$ be a nonmortar edge/face. We denote by $I(F)$ the set containing the indices of the subdomains that intersect F , and by π_F the mortar projection given on the edge/face F . We now provide the following bound for functions $v \in L^2(F)$ and with $\pi_F v = 0$ on ∂F .

LEMMA 4.4. *With Assumption 4.3 on the ρ_i , $w = (w_1, \dots, w_N) \in \tilde{W}$ satisfies*

$$\rho_i \|\pi_F(\phi - w_i)\|_{H_{00}^{1/2}(F)}^2 \leq C \left(1 + \log \frac{H_i}{h_i}\right)^3 \sum_{k \in I(F)} \langle S^{(k)} w_k, w_k \rangle,$$

where $F \subset \partial\Omega_i$ is a nonmortar edge/face.

Proof. For any function $v(x) \in L^2(F)$ or $L^2(\Omega_l)$, let us define

$$\hat{v}(x) = v(H_i x), \quad x \in \hat{F} \text{ or } \hat{\Omega}_l,$$

where H_i is the diameter of the Ω_i , and \hat{F} and $\hat{\Omega}_l$ denote the dilated sets. From the definition of the mortar projection, we see that

$$(4.5) \quad \widehat{\pi_F(v)} = \pi_{\hat{F}} \hat{v},$$

where $\pi_{\hat{F}}$ denotes the mortar projection based on the finite element space dilated by H_i .

We now consider

$$\|\pi_F(\phi - w_i)\|_{H_{00}^{1/2}(F)}^2 \leq 2\|\pi_F(\phi)\|_{H_{00}^{1/2}(F)}^2 + 2\|\pi_F(w_i)\|_{H_{00}^{1/2}(F)}^2.$$

Let

$$\tilde{\phi} = w_j - c_{ij}, \quad \tilde{w}_i = w_i - c_{ij} \quad \text{on } F_{ij} = \partial\Omega_j \cap \partial\Omega_i,$$

where

$$c_{ij} = \frac{\int_{F_{ij}} w_i \psi_{ij} ds}{\int_{F_{ij}} \psi_{ij} ds} = \frac{\int_{F_{ij}} w_j \psi_{ij} ds}{\int_{F_{ij}} \psi_{ij} ds}.$$

We then have $\tilde{\phi}, \tilde{w}_i \in H^{1/2-\epsilon}(F)$ for $0 < \epsilon \leq 1/2$ and $\phi - w_i = \tilde{\phi} - \tilde{w}_i$, and can thus replace ϕ and w_i above by $\tilde{\phi}$ and \tilde{w}_i , respectively.

By using a scaling argument and the identity (4.5), we have

$$\begin{aligned} \|\pi_F(\phi)\|_{H_0^{1/2}(F)}^2 &= H_i^{d-2} \|\widehat{\pi_F(\phi)}\|_{H_0^{1/2}(\widehat{F})}^2 \\ &= H_i^{d-2} \|\pi_{\widehat{F}}(\widehat{\phi})\|_{H_0^{1/2}(\widehat{F})}^2 \\ (4.6) \quad &\leq 2H_i^{d-2} \left(\|\pi_{\widehat{F}}(\widehat{\phi} - Q\widehat{\phi})\|_{H_0^{1/2}(\widehat{F})}^2 + \|\pi_{\widehat{F}}(Q\widehat{\phi})\|_{H_0^{1/2}(\widehat{F})}^2 \right), \end{aligned}$$

where $Q\widehat{\phi}$ is the L^2 -projection of $\widehat{\phi}$ on the finite element space $W_i(\widehat{F})$, i.e., the dilated finite element space provided for the nonmortar edge/face \widehat{F} .

From an inverse inequality, the continuity of $\pi_{\widehat{F}}$ in $L^2(\widehat{F})$, the approximation property of Q for a function $\widehat{\phi} \in H^{1/2-\epsilon}(\widehat{F})$, Lemma 4.2, and a scaling argument, we obtain

$$\begin{aligned} \|\pi_{\widehat{F}}(\widehat{\phi} - Q\widehat{\phi})\|_{H_0^{1/2}(\widehat{F})}^2 &\leq C\widehat{h}_i^{-1} \|\widehat{\phi} - Q\widehat{\phi}\|_{L^2(\widehat{F})}^2 \\ &\leq C\widehat{h}_i^{-1} \widehat{h}_i^{1-2\epsilon} \|\widehat{\phi}\|_{H^{1/2-\epsilon}(\widehat{F})}^2 \\ &\leq C\widehat{h}_i^{-2\epsilon} \epsilon^{-1} \sum_j \|\widehat{w}_j\|_{1/2, \partial\widehat{\Omega}_j}^2. \end{aligned}$$

Replacing $\widehat{\phi}$ with $\tilde{\phi}$ in the above estimate and using a Poincaré inequality and a scaling argument, we find

$$\begin{aligned} \|\pi_{\widehat{F}}(\tilde{\phi} - Q\widehat{\phi})\|_{H_0^{1/2}(\widehat{F})}^2 &\leq C\widehat{h}_i^{-2\epsilon} \epsilon^{-1} \sum_j |\widehat{w}_j|_{1/2, \partial\widehat{\Omega}_j}^2 \\ (4.7) \quad &\leq CH_i^{2-d} \widehat{h}_i^{-2\epsilon} \epsilon^{-1} \sum_j |w_j|_{1/2, \partial\Omega_j}^2. \end{aligned}$$

We now estimate

$$\begin{aligned} \|\pi_{\widehat{F}}(Q\widehat{\phi})\|_{H_0^{1/2}(\widehat{F})}^2 &= \left\| \pi_{\widehat{F}} \left(I_{\widehat{F}}(Q\widehat{\phi}) + Q\widehat{\phi} - I_{\widehat{F}}(Q\widehat{\phi}) \right) \right\|_{H_0^{1/2}(\widehat{F})}^2 \\ (4.8) \quad &\leq C \left(\|I_{\widehat{F}}(Q\widehat{\phi})\|_{H_0^{1/2}(\widehat{F})}^2 + \widehat{h}_i^{-1} \|Q\widehat{\phi} - I_{\widehat{F}}(Q\widehat{\phi})\|_{L^2(\widehat{F})}^2 \right), \end{aligned}$$

where $I_{\widehat{F}}(w_i)$ is the nodal value interpolant described in (4.4). Here, we have used that $\pi_{\widehat{F}}$ is a bounded map in $H_0^{1/2}(\widehat{F})$ as well as in $L^2(\widehat{F})$, and also used an inverse inequality. By using

Lemma 4.24 in [21], an inverse inequality, the stability of Q in $H^{1/2-\epsilon}(\widehat{F})$, Lemma 4.2, a Poincaré inequality, and a scaling argument, we obtain

$$\begin{aligned}
\|I_{\widehat{F}}(Q\widehat{\phi})\|_{H_{00}^{1/2}(\widehat{F})}^2 &\leq C \left(1 + \log \frac{H_i}{h_i}\right)^2 \|Q\widehat{\phi}\|_{H^{1/2}(\widehat{F})}^2 \\
&\leq C \left(1 + \log \frac{H_i}{h_i}\right)^2 \widehat{h}_i^{-2\epsilon} \|Q\widehat{\phi}\|_{H^{1/2-\epsilon}(\widehat{F})}^2 \\
&\leq C \left(1 + \log \frac{H_i}{h_i}\right)^2 \widehat{h}_i^{-2\epsilon} \|\widehat{\phi}\|_{H^{1/2-\epsilon}(\widehat{F})}^2 \\
&\leq C \left(1 + \log \frac{H_i}{h_i}\right)^2 \widehat{h}_i^{-2\epsilon} \epsilon^{-1} \sum_j \|\widehat{w}_j\|_{1/2, \partial\widehat{\Omega}_j}^2 \\
(4.9) \quad &\leq CH_i^{2-d} \left(1 + \log \frac{H_i}{h_i}\right)^2 \widehat{h}_i^{-2\epsilon} \epsilon^{-1} \sum_j |w_j|_{1/2, \partial\Omega_j}^2.
\end{aligned}$$

We note that $Q\widehat{\phi} - I_{\widehat{F}}(Q\widehat{\phi})$ has nonzero value only at the nodes on the boundary of \widehat{F} . In two dimensions, by using Lemma 4.15 in [21], we obtain

$$\begin{aligned}
\|Q\widehat{\phi} - I_{\widehat{F}}(Q\widehat{\phi})\|_{L^2(\widehat{F})}^2 &\leq C\widehat{h}_i \|Q\widehat{\phi}\|_{\infty, \widehat{F}}^2 \\
&\leq C\widehat{h}_i \left(1 + \log \frac{H_i}{h_i}\right) \|Q\widehat{\phi}\|_{H^{1/2}(\widehat{F})}^2
\end{aligned}$$

and in three dimensions, by using Lemma 4.17 in [21], we also obtain

$$\begin{aligned}
\|Q\widehat{\phi} - I_{\widehat{F}}(Q\widehat{\phi})\|_{L^2(\widehat{F})}^2 &\leq C\widehat{h}_i \|Q\widehat{\phi}\|_{L^2(\partial\widehat{F})}^2 \\
&\leq C\widehat{h}_i \left(1 + \log \frac{H_i}{h_i}\right) \|Q\widehat{\phi}\|_{H^{1/2}(\widehat{F})}^2.
\end{aligned}$$

The same estimate, as before, for the term $\|Q\widehat{\phi}\|_{H^{1/2}(\widehat{F})}^2$ gives

$$(4.10) \quad \|Q\widehat{\phi} - I_{\widehat{F}}(Q\widehat{\phi})\|_{L^2(\widehat{F})}^2 \leq CH_i^{2-d} \widehat{h}_i \left(1 + \log \frac{H_i}{h_i}\right) \widehat{h}_i^{-2\epsilon} \epsilon^{-1} \sum_j |w_j|_{1/2, \partial\Omega_j}^2.$$

Combining (4.6) with (4.7)-(4.10) results in

$$\rho_i \|\pi_F(\phi)\|_{H_{00}^{1/2}(F)}^2 \leq C \left(1 + \log \frac{H_i}{h_i}\right)^2 \widehat{h}_i^{-2\epsilon} \epsilon^{-1} \sum_j \frac{\rho_i}{\rho_j} \langle S^{(j)} w_j, w_j \rangle.$$

The desired bound follows by letting $\epsilon = 1/(2|\log \widehat{h}_i|)$ and using the assumption that $\rho_i/\rho_j \leq C$. We note that $\widehat{h}_i = h_i/H_i$ and $\log(\widehat{h}_i^{-2\epsilon}) = 1$. The same analysis applied to $\|\pi_F(w_i)\|_{H_{00}^{1/2}(F)}^2$ gives

$$\rho_i \|\pi_F(w_i)\|_{H_{00}^{1/2}(F)}^2 \leq C \left(1 + \log \frac{H_i}{h_i}\right)^3 \langle S^{(i)} w_i, w_i \rangle.$$

□

REMARK 4.5. *For the geometrically conforming case, Lemma 4.4 is valid with a factor $(1 + \log(H_i/h_i))^2$ using the same analysis as above. Therefore, in this case, we obtain a better condition number estimate; see also Remark 4.8 below. The estimate improves the one in [9, 11] by using the projection Q ; we do not need the assumption on the mesh sizes h_i and h_j*

$$\frac{h_j}{h_i} \leq C \left(\frac{\rho_j}{\rho_i} \right)^\gamma \quad \text{for some } 0 \leq \gamma \leq 1,$$

considered in [9, 11] where Ω_i is the nonmortar side and Ω_j is the mortar side.

With the help of Lemma 4.4, we can establish property (P2) for the operator E_D .

LEMMA 4.6. *With Assumption 4.3, the operator E_D satisfies*

$$|E_D w|_S^2 \leq C \max_i \left\{ \left(1 + \log \frac{H_i}{h_i} \right)^3 \right\} |w|_S^2.$$

Proof. Using the weight matrix D in (4.2), the average operator E_D in (4.1) is given by

$$E_D \begin{pmatrix} w_n \\ w_m \\ w_\Pi \end{pmatrix} = \begin{pmatrix} w_n - B_n^{-1}(B_n w_n + B_m w_m + B_\Pi w_\Pi) \\ w_m \\ w_\Pi \end{pmatrix},$$

see Remark 4.1. Let

$$z_n = w_n - B_n^{-1}(B_n w_n + B_m w_m + B_\Pi w_\Pi),$$

and construct z_i by restricting the unknowns (z_n, w_m, w_Π) to the subdomain Ω_i . Similarly, we construct w_i from (w_n, w_m, w_Π) . We note that (w_1, \dots, w_N) satisfies the primal constraints on the edges/faces. By definition, $z = (z_1, \dots, z_N) \in \widehat{W}$, i.e., z satisfies the mortar matching condition, and each z_i is of the form

$$z_i = w_i + \sum_{F \subset \partial\Omega_i} E_F^{(i)} \pi_F(\phi - w_i),$$

where F is a nonmortar edge/face in $\partial\Omega_i$, $E_F^{(i)}$ is the zero extension of functions defined on

F to all of $\partial\Omega_i \setminus F$, and $\phi = w_j$ on $F_{ij} := \partial\Omega_j \cap \partial\Omega_i \subset F$. We then obtain

$$\begin{aligned}
|E_D w|_{\tilde{S}}^2 &= \sum_{i=1}^N \langle S^{(i)} z_i, z_i \rangle \\
&\leq C \sum_{i=1}^N \left(\langle S^{(i)} w_i, w_i \rangle + \sum_{F \subset \partial\Omega_i} \langle S^{(i)} E_F^{(i)} \pi_F(\phi - w_i), E_F^{(i)} \pi_F(\phi - w_i) \rangle \right) \\
&\leq C \sum_{i=1}^N \langle S^{(i)} w_i, w_i \rangle + \sum_{i=1}^N \sum_{F \subset \partial\Omega_i} \rho_i \|\pi_F(\phi - w_i)\|_{H_0^{1/2}(F)}^2 \\
&\leq C \max_i \left\{ \left(1 + \log \frac{H_i}{h_i} \right)^3 \right\} \sum_{i=1}^N \langle S^{(i)} w_i, w_i \rangle \\
&\leq C \max_i \left\{ \left(1 + \log \frac{H_i}{h_i} \right)^3 \right\} \langle \tilde{S} w, w \rangle.
\end{aligned}$$

Here we have used that $\langle S^{(i)} w_i, w_i \rangle \simeq \rho_i |w_i|_{H^{1/2}(\partial\Omega_i)}^2$, the relation in (4.3), and Lemma 4.4.

□

By using the properties (P1) and (P2), we can show the following condition number bound of the BDDC operator (3.8). A similar proof is given in Li and Widlund [16] in an analysis of a BDDC algorithm for the Stokes problem with conforming meshes.

THEOREM 4.7. *With Assumption 4.3, we have the condition number bound*

$$\kappa(B_{DDC}) \leq C \max_i \left\{ \left(1 + \log \frac{H_i}{h_i} \right)^3 \right\}.$$

Proof. We let

$$M^{-1} = R_{D,\Gamma}^t \tilde{S}^{-1} R_{D,\Gamma}, \quad \hat{S} = R_{\Gamma}^t \tilde{S} R_{\Gamma},$$

and we then have

$$B_{DDC} = M^{-1} \hat{S}.$$

We will now provide a lower bound by proving

$$\langle u, u \rangle_{\tilde{S}} \leq \langle u, M^{-1} \hat{S} u \rangle_{\tilde{S}}.$$

Let $w = \tilde{S}^{-1} R_{D,\Gamma} \hat{S} u$. From property (P1), $R_{\Gamma}^t R_{D,\Gamma} = R_{D,\Gamma}^t R_{\Gamma} = I$, we obtain $u = \hat{S}^{-1} R_{\Gamma}^t \tilde{S} w$. We then consider

$$\begin{aligned}
\langle u, u \rangle_{\tilde{S}} &= u^t \hat{S} u \\
&= u^t R_{\Gamma}^t \tilde{S} w \\
&= \langle w, R_{\Gamma} u \rangle_{\tilde{S}} \\
&\leq \langle w, w \rangle_{\tilde{S}}^{1/2} \langle R_{\Gamma} u, R_{\Gamma} u \rangle_{\tilde{S}}^{1/2} \\
&\leq \langle w, w \rangle_{\tilde{S}}^{1/2} \langle u, u \rangle_{\tilde{S}}^{1/2}.
\end{aligned}$$

Here we have used the Cauchy-Schwarz inequality. Squaring and cancelling a common factor, we obtain

$$\langle u, u \rangle_{\widehat{S}} \leq \langle w, w \rangle_{\widehat{S}}.$$

By combining the above estimate with

$$\begin{aligned} \langle w, w \rangle_{\widehat{S}} &= u^t \widehat{S} R_{D,\Gamma}^t \widetilde{S}^{-1} \widetilde{S} \widetilde{S}^{-1} R_{D,\Gamma} \widehat{S} u \\ &= \langle u, R_{D,\Gamma}^t \widetilde{S}^{-1} R_{D,\Gamma} \widehat{S} u \rangle_{\widehat{S}} \\ (4.11) \quad &= \langle u, M^{-1} \widehat{S} u \rangle_{\widehat{S}}, \end{aligned}$$

we obtain the desired lower bound.

We will now find an upper bound by proving

$$\langle M^{-1} \widehat{S} u, M^{-1} \widehat{S} u \rangle_{\widehat{S}}^{1/2} \leq C \max_i \left\{ \left(1 + \log \frac{H_i}{h_i} \right)^3 \right\} \langle u, u \rangle_{\widehat{S}}^{1/2}.$$

We consider

$$\begin{aligned} \langle M^{-1} \widehat{S} u, M^{-1} \widehat{S} u \rangle_{\widehat{S}} &= \langle R_{D,\Gamma}^t w, R_{D,\Gamma}^t w \rangle_{\widehat{S}} \\ &= \langle R_{\Gamma} R_{D,\Gamma}^t w, R_{\Gamma} R_{D,\Gamma}^t w \rangle_{\widehat{S}} \\ &= |E_D w|_{\widehat{S}}^2 \\ &\leq C \max_i \left\{ \left(1 + \log \frac{H_i}{h_i} \right)^3 \right\} |w|_{\widehat{S}}^2. \end{aligned}$$

The last inequality follows from Lemma 4.6. Combining the above estimate with (4.11), we obtain

$$\langle M^{-1} \widehat{S} u, M^{-1} \widehat{S} u \rangle_{\widehat{S}} \leq C \max_i \left\{ \left(1 + \log \frac{H_i}{h_i} \right)^3 \right\} \langle u, M^{-1} \widehat{S} u \rangle_{\widehat{S}}.$$

By applying the Cauchy-Schwarz inequality to the term $\langle u, M^{-1} \widehat{S} u \rangle_{\widehat{S}}$, the desired upper bound follows. \square

REMARK 4.8. *The analysis above can be modified for the geometrically conforming case and leads to the condition number bound*

$$\kappa(B_{DDC}) \leq C \max_i \left\{ \left(1 + \log \frac{H_i}{h_i} \right)^2 \right\},$$

when Assumption 4.3 holds; see Remark 4.5.

REMARK 4.9. *For a geometrically non-conforming partition, the number of primal constraints tends to be bigger than for a conforming partition in case only edge/face constraints are used. We note that there have been several previous studies which explore the possibility of selecting primal constraints for only some of the edges/faces; see [10, 14, 15].*

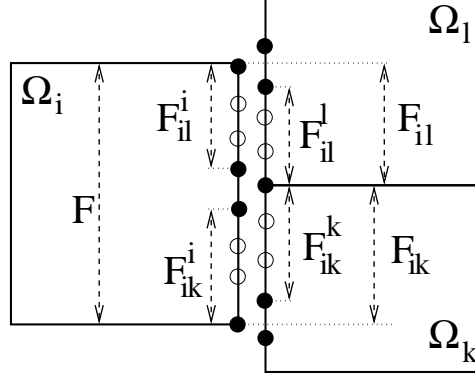

FIG. 4.1. Geometrically non-conforming partition: white circles (nodes in $\mathcal{V}_j^{ij} (\subset \partial\Omega_j)$, $j = l, k$ or $\mathcal{V}_i^{ij} (\subset \partial\Omega_i)$, $j = l, k$), black circles (nodes in $\mathcal{N}_j^{ij} (\subset \partial\Omega_j)$, $j = l, k$ or $\mathcal{N}_i^{ij} (\subset \partial\Omega_i)$, $j = l, k$), each faces F , F_{il} , F_{ik} and F_{ij}^j for $j = l, k$ are described.

We will now provide a better estimate for geometrically non-conforming partitions under an assumption on the meshes that is considered in [9, 11]. We will prove our result only for the two-dimensional case; in three dimensions there are some additional technical difficulties. We conjecture that the result also holds in that case.

ASSUMPTION 4.10. The mesh sizes h_i and h_j satisfy

$$\frac{h_j}{h_i} \leq C \left(\frac{\rho_j}{\rho_i} \right)^\gamma \quad \text{for some } 0 \leq \gamma \leq 1,$$

where Ω_i is the nonmortar side and Ω_j is the mortar side.

LEMMA 4.11. With Assumptions 4.3 and 4.10, $(w_1, \dots, w_N) \in \widetilde{W}$ satisfies

$$\rho_i \|\pi_F(\phi - w_i)\|_{H_{00}^{1/2}(F)}^2 \leq C \max_{k \in I(F)} \left\{ \left(1 + \log \frac{H_k}{h_k} \right)^2 \right\} \sum_{k \in I(F)} \langle S^{(k)} w_k, w_k \rangle,$$

where $F \subset \partial\Omega_i$ is a nonmortar edge/face and $I(F)$ is the set of the indices of the subdomains that intersect F .

Proof. We consider the case in Figure 4.1. The nonmortar edge $F \subset \partial\Omega_i$ is partitioned into F_{il} and F_{ik} and ϕ is given by w_j on F_{ij} , $j = l, k$. Since the function $(w_1, \dots, w_N) \in \widetilde{W}$ satisfies the primal constraints, we have

$$\int_{F_{ij}} (\phi - w_i) \psi_{ij} ds = \int_{F_{ij}} (w_j - w_i) \psi_{ij} = 0, \quad j = l, k,$$

and we then define

$$c_{ij} = \frac{\int_{F_{ij}} w_i \psi_{ij} ds}{\int_{F_{ij}} \psi_{ij} ds} = \frac{\int_{F_{ij}} w_j \psi_{ij} ds}{\int_{F_{ij}} \psi_{ij} ds}, \quad j = l, k.$$

Let

$$\tilde{w}_i = w_i - c_{ij} \quad \text{and} \quad \tilde{\phi} = w_j - c_{ij} \quad \text{on } F_{ij}, \quad j = l, k.$$

We note that $\phi - w_i = \tilde{\phi} - \tilde{w}_i$.

Let \mathcal{V}_i^{ij} be the set of nodes in \mathcal{V}_i with nodal basis functions supported in F_{ij} . We denote by F_{ij}^i the union of these supports. We note that $F_{ij}^i \subset F_{ij}$. The set \mathcal{V}_j^{ij} and F_{ij}^j are defined similarly; see Figure 4.1.

Let \mathcal{N}_i^{ij} be the set of nodes in $\mathcal{V}_i \setminus \mathcal{V}_i^{ij}$ with nodal basis functions with support that intersects F_{ij} . The set \mathcal{N}_j^{ij} is defined similarly. In general, we may assume that the number of nodes in each set \mathcal{N}_j^{ij} and \mathcal{N}_i^{ij} is bounded uniformly with respect to the mesh parameters.

We consider

(4.12)

$$\begin{aligned} \|\pi_F(\phi - w_i)\|_{H_0^{1/2}(F)}^2 &= \left\| \pi_F \left(\sum_{j=l,k} I_{F_{ij}^j}(w_j - c_{ij}) - \sum_{j=l,k} I_{F_{ij}^i}(w_i - c_{ij}) \right. \right. \\ &\quad \left. \left. + \tilde{\phi} - \sum_{j=l,k} I_{F_{ij}^j}(w_j - c_{ij}) - \tilde{w}_i + \sum_{j=l,k} I_{F_{ij}^i}(w_i - c_{ij}) \right) \right\|_{H_0^{1/2}(F)}^2. \end{aligned}$$

Since the first two terms in the above equation are in $H_0^{1/2}(F)$, the continuity of the mortar projection in $H_0^{1/2}(F)$ and Lemma 4.24 in [21] give

$$\begin{aligned} \|\pi_F(I_{F_{ij}^j}(w_j - c_{ij}))\|_{H_0^{1/2}(F)}^2 &\leq C \|I_{F_{ij}^j}(w_j - c_{ij})\|_{H_0^{1/2}(F)}^2 \\ &= C \|I_{F_{ij}^j}(w_j - c_{ij})\|_{H_0^{1/2}(F_{ij}^j)}^2 \\ (4.13) \quad &\leq C \left(1 + \log \frac{H_j}{h_j}\right)^2 \|w_j - c_{ij}\|_{H^{1/2}(\partial\Omega_j)}^2, \end{aligned}$$

and

$$(4.14) \quad \|\pi_F(I_{F_{ij}^i}(w_i - c_{ij}))\|_{H_0^{1/2}(F)}^2 \leq C \left(1 + \log \frac{H_i}{h_i}\right)^2 \|w_i - c_{ij}\|_{H^{1/2}(\partial\Omega_i)}^2.$$

We now bound the third term in (4.12) as follows:

$$\begin{aligned} &\|\pi_F(\tilde{\phi} - \sum_{j=l,k} I_{F_{ij}^j}(w_j - c_{ij}))\|_{H_0^{1/2}(F)}^2 \\ &\leq Ch_i^{-1} \|\pi_F(\tilde{\phi} - \sum_{j=l,k} I_{F_{ij}^j}(w_j - c_{ij}))\|_{L^2(F)}^2 \\ &\leq Ch_i^{-1} \|\tilde{\phi} - \sum_{j=l,k} I_{F_{ij}^j}(w_j - c_{ij})\|_{L^2(F)}^2 \\ (4.15) \quad &\leq Ch_i^{-1} \sum_{j=l,k} \|w_j - c_{ij} - I_{F_{ij}^j}(w_j - c_{ij})\|_{L^2(F_{ij}^j)}^2 \\ &\leq Ch_i^{-1} \sum_{j=l,k} h_j \|w_j - c_{ij}\|_{L^\infty(\partial\Omega_j)}^2 \\ (4.16) \quad &\leq Ch_i^{-1} \sum_{j=l,k} h_j \left(1 + \log \frac{H_j}{h_j}\right)^2 \|w_j - c_{ij}\|_{H^{1/2}(\partial\Omega_j)}^2. \end{aligned}$$

We have used an inverse inequality, the continuity of π_F in $L^2(F)$ and Lemma 4.15 in [21]. The expression in (4.15) has nonzero values at the nodes in \mathcal{N}_j^{ij} . By using the fact that the number of nodes in \mathcal{N}_j^{ij} is bounded independently of any mesh parameters (at most three in Figure 4.1), we have

$$\|w_j - c_{ij} - I_{F_{ij}^j}(w_j - c_{ij})\|_{L^2(F_{ij}^j)}^2 \leq Ch_j \|w_j - c_{ij}\|_{L^\infty(\partial\Omega_j)}^2.$$

Similarly, we have a bound for the last term in (4.12):

$$(4.17) \quad \begin{aligned} & \|\pi_F(\tilde{w}_i - \sum_{j=l,k} I_{F_{ij}^i}(w_i - c_{ij}))\|_{H_{00}^{1/2}(F)}^2 \\ & \leq C \left(1 + \log \frac{H_i}{h_i}\right) \sum_{j=l,k} \|w_i - c_{ij}\|_{H^{1/2}(\partial\Omega_i)}^2. \end{aligned}$$

As a result, (4.12), (4.13), (4.14), (4.16), and (4.17) give

$$\begin{aligned} \|\pi_F(\phi - w_i)\|_{H_{00}^{1/2}(F)}^2 & \leq C \max_{k \in I(F)} \left\{ \left(1 + \log \frac{H_k}{h_k}\right)^2 \right\} \\ & \quad \sum_{j=l,k} \left(\|w_i - c_{ij}\|_{H^{1/2}(\partial\Omega_i)}^2 + \left(1 + \frac{h_j}{h_i}\right) \|w_j - c_{ij}\|_{H^{1/2}(\partial\Omega_j)}^2 \right). \end{aligned}$$

A Poincaré inequality can be applied to the functions $w_i - c_{ij}$ and $w_j - c_{ij}$ and this replaces the norms by semi-norms. By using the relation

$$\rho_i |w_i|_{H^{1/2}(\partial\Omega_i)}^2 \simeq \langle S^{(i)} w_i, w_i \rangle,$$

we obtain the following bound

$$\begin{aligned} \rho_i \|\pi_F(\phi - w_i)\|_{H_{00}^{1/2}(F)}^2 & \leq C \max_{k \in I(F)} \left\{ \left(1 + \log \frac{H_k}{h_k}\right)^2 \right\} \\ & \quad \sum_{j=l,k} \left(\langle S^{(i)} w_i, w_i \rangle + \left(1 + \frac{h_j}{h_i}\right) \frac{\rho_i}{\rho_j} \langle S^{(j)} w_j, w_j \rangle \right). \end{aligned}$$

By using Assumptions 4.3 and 4.10, we then have

$$\left(1 + \frac{h_j}{h_i}\right) \frac{\rho_i}{\rho_j} \leq C \left(1 + \left(\frac{\rho_i}{\rho_j}\right)^{1-\gamma}\right) \leq C.$$

Therefore the required bound holds with a constant C which does not depend further on the mesh parameters and the jumps of the coefficients. \square

By using Lemma 4.11 and the same analysis as in Theorem 4.4, we obtain a better condition number bound for the geometrically non-conforming case.

THEOREM 4.12. *For a geometrically non-conforming subdomain partition and in two dimensions, the BDDC operator satisfies*

$$\kappa(B_{DDC}) \leq C \max_i \left\{ \left(1 + \log \frac{H_i}{h_i}\right)^2 \right\},$$

when Assumptions 4.3 and 4.10 hold.

5. A connection between FETI–DP and BDDC methods. In this section, we will show that the BDDC algorithm developed in the previous sections is closely connected to the FETI–DP algorithm developed by the first author in [9, 10] and by her jointly with Lee in [11]. These two algorithms will be shown to share the same spectra except possibly for an eigenvalue equal to 1.

A study comparing the spectra of the BDDC algorithm to that of the FETI–DP algorithm was carried out by Mandel, Dohrmann and Tezaur [20] for conforming finite elements. They showed that these two algorithms have the same set of eigenvalues except possibly for eigenvalues equal to 0 and 1. Recently, a quite simple proof of this fact was given by Li and Widlund [17]. They formulated the BDDC operators as well as the FETI–DP operators using a change of variables and introducing certain projections and average operators. These projections and average operators provide an important connection between the FETI–DP and the BDDC operators.

We first formulate a FETI–DP operator with the change of variables introduced in Section 2.2. We then show that the FETI–DP operator has essentially the same spectrum as the BDDC operator by establishing several properties of the projections and average operators that are used in the analysis by Li and Widlund [17].

After the change of variables, the linear system considered in the FETI–DP formulation is given by

$$(5.1) \quad \begin{pmatrix} S_{\Delta\Delta} & S_{\Delta\Pi} & B_{\Delta}^t \\ S_{\Pi\Delta} & S_{\Pi\Pi} & B_{\Pi}^t \\ B_{\Delta} & B_{\Pi} & 0 \end{pmatrix} \begin{pmatrix} u_{\Delta} \\ u_{\Pi} \\ \lambda \end{pmatrix} = \begin{pmatrix} g_{\Delta} \\ g_{\Pi} \\ 0 \end{pmatrix},$$

where the matrices $S_{\Delta\Delta}$, $S_{\Delta\Pi}$, $S_{\Pi\Delta}$, and $S_{\Pi\Pi}$ are defined in (2.11) and the matrices B_{Δ} and B_{Π} are obtained from the mortar matching condition (2.8). We note that the subscripts Π and Δ stand for the unknowns or submatrices related to the primal variables and the remaining part, respectively, and that $\lambda \in \overline{M}$, the non-redundant Lagrange multiplier space.

After eliminating the unknowns u_{Δ} and u_{Π} , we obtain an equation for $\lambda \in \overline{M}$:

$$(5.2) \quad B_{\Gamma} \tilde{S}^{-1} B_{\Gamma}^t \lambda = d,$$

where

$$(5.3) \quad B_{\Gamma} = \begin{pmatrix} B_{\Delta} & B_{\Pi} \end{pmatrix}, \quad \tilde{S} = \begin{pmatrix} S_{\Delta\Delta} & S_{\Delta\Pi} \\ S_{\Pi\Delta} & S_{\Pi\Pi} \end{pmatrix},$$

and d is also the result of Gaussian elimination.

We will now express the Neumann-Dirichlet preconditioner considered in [9, 10, 11] using the change of variables. We recall the space W_n , defined in (2.4) and then define

$$\widetilde{W}_n := \left\{ w_n \in W_n : \int_{F_{ij}} w_n \psi_{ij} ds = 0, \quad \forall F_{ij}, \forall F \subset \partial\Omega_i, \forall i \right\},$$

where $F \subset \partial\Omega_i$ are nonmortar edges/faces with the partition $\{F_{ij}\}_j$. For the geometrically conforming case, the space \widetilde{W}_n consists of functions with zero average on each nonmortar edge/face F because $\psi_{ij} = 1$.

The Neumann-Dirichlet preconditioner M_{DP}^{-1} is defined by

$$(5.4) \quad \langle M_{DP}\lambda, \lambda \rangle = \max_{w_n \in \widetilde{W}_n} \frac{\langle BE(w_n), \lambda \rangle^2}{\langle SE(w_n), E(w_n) \rangle},$$

where $E(w_n)$ is the zero extension of w_n to all the interfaces and $B = (B^{(1)} \dots B^{(N)})$. Here we consider $\lambda \in \overline{M}$, a non-redundant Lagrange multiplier space, and hence the mortar matching matrix B has one less row for each nonmortar edge/face than in the original formulation in [9, 10, 11].

We recall the space W_Δ given in (2.7) and note that it can be split into

$$W_\Delta = W_{\Delta,n} \oplus W_{\Delta,m},$$

where n and m denote the unknowns of the nonmortar edges/faces and mortar edges/faces, respectively. The vectors in these spaces are represented by the unknowns after the change of variables. The space $W_{\Delta,n}$ is then identical to \widetilde{W}_n except that the bases are different.

By using the change of variables, (5.4) can be written as

$$(5.5) \quad \langle M_{DP}\lambda, \lambda \rangle = \max_{w_{\Delta,n} \in W_{\Delta,n}} \frac{\langle \widehat{B} \widehat{E}(w_{\Delta,n}), \lambda \rangle^2}{\langle \widehat{S} \widehat{E}(w_{\Delta,n}), \widehat{E}(w_{\Delta,n}) \rangle},$$

where

$$\widehat{B} = \begin{pmatrix} \widehat{B}^{(1)} & \dots & \widehat{B}^{(N)} \end{pmatrix}, \quad \widehat{S} = \text{diag}(\widehat{S}^{(i)}).$$

The matrices \widehat{S} and \widehat{B} act on the new unknowns $w_\Delta^{(i)}$ and $w_\Pi^{(i)}$ that result from the change of variables. The extension $\widehat{E}(w_{\Delta,n}) = (w_1, \dots, w_N)$ is given by

$$w_i = \begin{pmatrix} w_\Delta^{(i)} \\ w_\Pi^{(i)} \end{pmatrix},$$

where $w_\Delta^{(i)}$ is zero on the mortar edges/faces, $w_\Delta^{(i)}$ is equal to $w_{\Delta,n}$ on the nonmortar edges/faces, and $w_\Pi^{(i)}$ is zero.

The formula (5.5) can be written as

$$(5.6) \quad \langle M_{DP}\lambda, \lambda \rangle = \max_{w_{\Delta,n} \in W_{\Delta,n}} \frac{\langle B_n w_{\Delta,n}, \lambda \rangle^2}{\langle S_{nn} w_{\Delta,n}, w_{\Delta,n} \rangle}.$$

Here the matrices B_n and S_{nn} are submatrices of B_Δ and $S_{\Delta\Delta}$ in (5.1) corresponding to the nonmortar part. We see that $S_{nn} : W_{\Delta,n} \rightarrow W_{\Delta,n}$ and $B_n : W_{\Delta,n} \rightarrow \overline{M}$ are invertible. The maximum in (5.6) occurs when $S_{nn} w_{\Delta,n} = B_n^t \lambda$ and hence it follows that

$$M_{DP}^{-1} = (B_n^t)^{-1} S_{nn} B_n^{-1}.$$

Further this matrix can be written as

$$(5.7) \quad M_{DP}^{-1} = B_{\Sigma, \Gamma} \tilde{S} B_{\Sigma, \Gamma}^t,$$

where

$$B_{\Sigma, \Gamma}^t = \begin{pmatrix} \Sigma_{nn} & & \\ & \Sigma_{mm} & \\ & & \Sigma_{\Pi\Pi} \end{pmatrix} \begin{pmatrix} B_n^t \\ B_m^t \\ B_\Pi^t \end{pmatrix}$$

with the weights given by

$$\Sigma_{nn} = (B_n^t B_n)^{-1}, \quad \Sigma_{mm} = 0, \quad \Sigma_{\Pi\Pi} = 0.$$

Here the matrix B_m is a submatrix of B_Δ corresponding to the unknowns of the mortar part.

Therefore the FETI-DP operator with the Neumann-Dirichlet preconditioner M_{DP}^{-1} is given by

$$M_{DP}^{-1} F_{DP} = B_{\Sigma, \Gamma} \tilde{S} B_{\Sigma, \Gamma}^t B_\Gamma \tilde{S}^{-1} B_\Gamma^t,$$

while the preconditioned BDDC operator is given by

$$B_{DDC} = R_{D, \Gamma}^t \tilde{S}^{-1} R_{D, \Gamma} R_\Gamma^t \tilde{S} R_\Gamma.$$

Let us now define the following jump and average operators

$$P_\Sigma = B_{\Sigma, \Gamma}^t B_\Gamma, \quad E_D = R_\Gamma R_{D, \Gamma}^t.$$

The following results are provided in [17, Section 5].

THEOREM 5.1. *Assume that P_Σ and E_D satisfy*

1. $E_D + P_\Sigma = I$,
2. $E_D^2 = E_D$, $P_\Sigma^2 = P_\Sigma$,
3. $E_D P_\Sigma = P_\Sigma E_D = 0$.

Then the operators $M_{DP}^{-1} F_{DP}$ and B_{DDC} have the same eigenvalues except possibly for the eigenvalue equal to 1.

We will now show that the assumptions in Theorem 5.1 hold for the operators P_Σ and E_D . We express the space \tilde{W} by using the unknowns w_n , w_m , and w_Π :

$$\tilde{W} = \{(w_n^t, w_m^t, w_\Pi^t)^t : \forall w_n, w_m, w_\Pi\},$$

and we recall the mortar finite element space

$$\widehat{W} = \{w \in \tilde{W} : B_m w_m + B_\Pi w_\Pi + B_n w_n = 0\}.$$

We note that P_Σ and E_D are operators defined on the space \widehat{W} .

LEMMA 5.2. *The operators P_Σ and E_D satisfy*

1. $E_D + P_\Sigma = I$,
2. $E_D^2 = E_D$, $P_\Sigma^2 = P_\Sigma$,
3. $E_D P_\Sigma = P_\Sigma E_D = 0$.

Proof. From

$$\begin{aligned}\Sigma_{mm} &= 0, \quad \Sigma_{\text{III}} = 0, \quad \Sigma_{nn} = (B_n^t B_n)^{-1}, \\ D_{mm} &= I, \quad D_{\text{III}} = I, \quad D_{nn} = 0,\end{aligned}$$

we have

$$\begin{aligned}P_\Sigma w &= \begin{pmatrix} B_n^{-1}(B_m w_m + B_\Pi w_\Pi + B_n w_n) \\ 0 \\ 0 \end{pmatrix}, \\ E_D w &= \begin{pmatrix} -B_n^{-1}(B_m w_m + B_\Pi w_\Pi) \\ w_m \\ w_\Pi \end{pmatrix}.\end{aligned}$$

Hence,

$$E_D + P_\Sigma = I.$$

We will now show that $E_D^2 = E_D$. Since $\text{Range}(E_D) \in \widehat{W}$ and $E_D w = w$ for all $w \in \widehat{W}$, we obtain

$$E_D(E_D w) = E_D w \text{ for all } w \in \widehat{W}.$$

This implies that

$$(5.8) \quad E_D^2 = E_D.$$

From $E_D + P_\Sigma = I$ and $E_D^2 = E_D$, we have

$$E_D(E_D + P_\Sigma) = E_D$$

and therefore

$$E_D P_\Sigma = 0.$$

Moreover, from $P_\Sigma w = 0$ for all $w \in \widehat{W}$ and $\text{Range}(E_D) \in \widehat{W}$, we can show that

$$P_\Sigma E_D = 0.$$

To show that $P_\Sigma^2 = P_\Sigma$, we consider

$$P_\Sigma(E_D + P_\Sigma) = P_\Sigma,$$

and from $P_\Sigma E_D = 0$, we obtain

$$P_\Sigma^2 = P_\Sigma.$$

□

REMARK 5.3. *Other FETI–DP preconditioners in two dimensions with different weights*

$$\Sigma = \begin{pmatrix} \Sigma_{nn} & & \\ & \Sigma_{mm} & \\ & & \Sigma_{\text{III}} \end{pmatrix}$$

have been developed and shown to give a condition number bound

$$C \max_i \{ (1 + \log(H_i/h_i))^2 \}$$

for some geometrically conforming cases with nonzero weights Σ_{mm} and Σ_{III} ; see [6, 5]. We have not found a weight matrix D that results in $E_D + P_\Sigma = I$ for such a choice of Σ .

6. Numerical tests. In this section, we discuss numerical tests which compare the efficiency of the BDDC method and that of the FETI–DP method. For $\Omega = [0, 1]^2$, we solve the elliptic problem with the exact solution $u(x, y) = \sin(\pi x)(1 - y)y$;

$$\begin{aligned} -\Delta u &= f \quad \text{in } \Omega, \\ u &= 0 \quad \text{on } \partial\Omega. \end{aligned}$$

We have carried out experiments for both matching and non-matching grids employing the mortar matching conditions across the interfaces. The CG (Conjugate Gradient) iteration continues until the residual norm has been reduced by a factor 10^{-6} .

The domain Ω is divided into square subdomains as in Figure 6.1. For matching grids, we introduce uniform meshes with n nodes on each horizontal and vertical edge. To make the meshes non-matching across subdomain interfaces, we generate triangulations in each subdomain in the following way: for each subdomain, we choose n random quasi-uniform nodes on each horizontal and vertical edges. From these nodes, we generate nonuniform structured grids in each subdomain. Since we choose the same number of quasi-uniform nodes n for all subdomains, the mesh sizes of neighboring subdomains are comparable.

First, we compare the two algorithms with the matching grids employing the mortar matching condition and primal constraints at the vertices. In Table 6.1, we divide Ω into $N = 4 \times 4$ subdomains (see Figure 6.1) and increase the number of nodes n . We compute L^2 - and H^1 -errors between the exact solution and the solution of the iterative method, the number of CG iterations, and the minimum and the maximum eigenvalues of the BDDC and the FETI–DP operators. For the H^1 -error, we compute the broken H^1 -norm based on the subdomain partition. Table 6.2 shows the numerical results when we fix $n - 1 = 4$ and

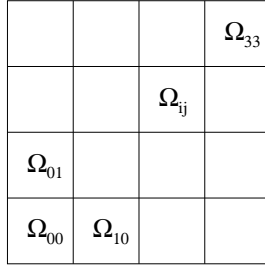
FIG. 6.1. Partition of subdomains when $N = 4 \times 4$

increase N , the number of subdomains. For $N = 8 \times 8$, 16×16 and 32×32 , we divide Ω into square subdomains in the same manner as for $N = 4 \times 4$. We see that both methods gives the same accuracy. The minimum eigenvalues of the BDDC operator are always equal to 1 while those of the FETI-DP operator are greater than 1. The maximum eigenvalues of both operators are almost the same.

In Table 6.3 and 6.4, we perform the same computations for non-matching grids. The results shows similar patterns for the minimum and maximum eigenvalues as for matching grids except that the minimum eigenvalues of FETI-DP operator converge to 1 when the number of nodes increases; see Table 6.3.

From the numerical results, we see that the BDDC operator always has the minimum eigenvalue 1 while the FETI-DP operator has all its eigenvalues greater than 1 and that these operators have almost the same maximum eigenvalues. Generally, we can conclude that the two algorithms perform quite similarly. Numerical tests on geometrically nonconforming partitions will be done in further research.

TABLE 6.1

(Matching grids) Comparison of FETI-DP and BDDC methods when n increases with a fixed number of subdomain $N = 4 \times 4$

| $n - 1$ | $\ u - u^h\ _0$ | $\ u - u^h\ _1$ | $M_{DP}^{-1}F_{DP}$ | | | B_{DDC} | | |
|---------|-----------------|-----------------|---------------------|------------------|------------------|-----------|------------------|------------------|
| | | | Iter | λ_{\min} | λ_{\max} | Iter | λ_{\min} | λ_{\max} |
| 4 | 4.1293e-4 | 5.7497e-2 | 10 | 1.43 | 4.01 | 11 | 1.00 | 4.01 |
| 8 | 1.0399e-4 | 2.8798e-2 | 12 | 1.35 | 5.64 | 13 | 1.00 | 5.64 |
| 16 | 2.6057e-5 | 1.4405e-2 | 14 | 1.31 | 7.64 | 15 | 1.00 | 7.64 |
| 32 | 6.5183e-6 | 7.2036e-3 | 15 | 1.31 | 1.00e+1 | 16 | 1.00 | 1.00e+1 |
| 64 | 1.6315e-6 | 3.6019e-3 | 16 | 1.35 | 1.27e+1 | 18 | 1.00 | 1.27e+1 |

REFERENCES

- [1] F. B. BELGACEM AND Y. MADAY, *The mortar element method for three dimensional finite elements*, M^2AN Math. Model. Numer. Anal., 31 (1997), pp. 289–302.

TABLE 6.2

(Matching grids) Comparison of FETI-DP and BDDC methods when N increases with a fixed number of nodes ($n - 1 = 4$) in each subdomain

| N | $\ u - u^h\ _0$ | $\ u - u^h\ _1$ | $M_{DP}^{-1}F_{DP}$ | | | B_{DDC} | | |
|----------------|-----------------|-----------------|---------------------|------------------|------------------|-----------|------------------|------------------|
| | | | Iter | λ_{\min} | λ_{\max} | Iter | λ_{\min} | λ_{\max} |
| 4×4 | 4.1293e-4 | 5.7497e-2 | 10 | 1.43 | 4.01 | 11 | 1.00 | 4.01 |
| 8×8 | 1.0399e-4 | 2.8798e-2 | 11 | 1.39 | 4.21 | 12 | 1.00 | 4.21 |
| 16×16 | 2.6057e-5 | 1.4405e-2 | 11 | 1.39 | 4.20 | 12 | 1.00 | 4.26 |
| 32×32 | 6.5183e-6 | 7.2036e-3 | 11 | 1.41 | 4.20 | 12 | 1.00 | 4.27 |

TABLE 6.3

(Non-matching grids) Comparison of FETI-DP and BDDC methods when n increases with a fixed number of subdomain $N = 4 \times 4$

| $n - 1$ | $\ u - u^h\ _0$ | $\ u - u^h\ _1$ | $M_{DP}^{-1}F_{DP}$ | | | B_{DDC} | | |
|---------|-----------------|-----------------|---------------------|------------------|------------------|-----------|------------------|------------------|
| | | | Iter | λ_{\min} | λ_{\max} | Iter | λ_{\min} | λ_{\max} |
| 4 | 5.0850e-4 | 6.0126e-2 | 10 | 1.40 | 4.09 | 12 | 1.00 | 4.09 |
| 8 | 1.2865e-4 | 3.0128e-2 | 13 | 1.01 | 5.72 | 15 | 1.00 | 5.72 |
| 16 | 3.2231e-5 | 1.5072e-2 | 15 | 1.00 | 7.72 | 16 | 1.00 | 7.72 |
| 32 | 8.0621e-6 | 7.5374e-3 | 16 | 1.01 | 1.00e+1 | 17 | 1.00 | 1.00e+1 |
| 64 | 2.0134e-6 | 3.7688e-3 | 17 | 1.01 | 1.28e+1 | 19 | 1.00 | 1.28e+1 |

- [2] C. BERNARDI AND Y. MADAY, *Spectral, spectral element and mortar element methods*, tech. report, Berlin, 2001.
- [3] C. BERNARDI, Y. MADAY, AND A. T. PATERA, *A new nonconforming approach to domain decomposition: the mortar element method*, in *Nonlinear partial differential equations and their applications*. Collège de France Seminar, Vol. XI (Paris, 1989–1991), vol. 299 of Pitman Res. Notes Math. Ser., Longman Sci. Tech., Harlow, 1994, pp. 13–51.
- [4] C. R. DOHRMANN, *A preconditioner for substructuring based on constrained energy minimization*, *SIAM J. Sci. Comput.*, 25 (2003), pp. 246–258.
- [5] N. DOKEVA, M. DRYJA, AND W. PROSKUROWSKI, *A FETI-DP preconditioner with special scaling for mortar discretization of elliptic problems with discontinuous coefficients*, to appear in *SIAM J. Numer. Anal.*, (2005).
- [6] M. DRYJA AND O. B. WIDLUND, *A generalized FETI-DP method for a mortar discretization of elliptic problems*, in *Domain decomposition methods in science and engineering*, Natl. Auton. Univ. Mex., México, 2003, pp. 27–38. Proceedings of the 14th international conference in domain decomposition methods.
- [7] P. GRISVARD, *Elliptic problems in nonsmooth domains*, vol. 24 of Monographs and Studies in Mathematics, Pitman (Advanced Publishing Program), Boston, MA, 1985.
- [8] C. KIM, R. D. LAZAROV, J. E. PASCIAK, AND P. S. VASSILEVSKI, *Multiplier spaces for the mortar finite element method in three dimensions*, *SIAM J. Numer. Anal.*, 39 (2001), pp. 519–538.
- [9] H. H. KIM, *A preconditioner for the FETI-DP formulation with mortar methods in three dimensions*, tech. report, KAIST, 2004.
- [10] ———, *A FETI-DP formulation of three dimensional elasticity problems with mortar discretization*, tech. report, New York University, 2005.

TABLE 6.4

(Non-matching grids) Comparison of FETI-DP and BDDC methods when N increases with a fixed number of nodes ($n - 1 = 4$) in each subdomain

| N | $\ u - u^h\ _0$ | $\ u - u^h\ _1$ | $M_{DP}^{-1}F_{DP}$ | | | B_{DDC} | | |
|----------------|-----------------|-----------------|---------------------|------------------|------------------|-----------|------------------|------------------|
| | | | Iter | λ_{\min} | λ_{\max} | Iter | λ_{\min} | λ_{\max} |
| 4×4 | 5.0850e-4 | 6.0126e-2 | 10 | 1.40 | 4.09 | 12 | 1.00 | 4.09 |
| 8×8 | 1.1744e-4 | 2.9900e-2 | 11 | 1.37 | 4.41 | 12 | 1.00 | 4.41 |
| 16×16 | 2.9743e-5 | 1.4980e-2 | 12 | 1.32 | 4.49 | 13 | 1.00 | 4.49 |
| 32×32 | 7.4317e-6 | 7.4917e-3 | 12 | 1.30 | 4.57 | 13 | 1.00 | 4.62 |

- [11] H. H. KIM AND C.-O. LEE, *A preconditioner for the FETI-DP formulation with mortar methods in two dimensions*, SIAM J. Numer. Anal., 42 (2005), pp. 2159–2175.
- [12] A. KLAWONN AND O. RHEINBACH, *A parallel implementation of Dual-Primal FETI methods for three dimensional linear elasticity using a transformation of basis*, tech. report, Technical Report SM-E-601, University of Essen, 2005.
- [13] ———, *Robust FETI-DP methods for heterogeneous three dimensional elasticity problems*, tech. report, Preprint, 2005.
- [14] A. KLAWONN AND O. B. WIDLUND, *Dual-Primal FETI methods for linear elasticity*, tech. report, New York University, 2004.
- [15] A. KLAWONN, O. B. WIDLUND, AND M. DRYJA, *Dual-primal FETI methods for three-dimensional elliptic problems with heterogeneous coefficients*, SIAM J. Numer. Anal., 40 (2002), pp. 159–179.
- [16] J. LI AND O. WIDLUND, *BDDC algorithms for incompressible Stokes equations*, tech. report, New York University, 2005.
- [17] ———, *FETI-DP, BDDC, and block Cholesky methods*, (2005).
- [18] ———, *On the use of inexact subdomain solvers for BDDC algorithms*, tech. report, New York University, 2005.
- [19] J. MANDEL AND C. R. DOHRMANN, *Convergence of a balancing domain decomposition by constraints and energy minimization*, Numer. Linear Algebra Appl., 10 (2003), pp. 639–659.
- [20] J. MANDEL, C. R. DOHRMANN, AND R. TEZAU, *An algebraic theory for Primal and Dual substructuring methods by constraints*, Appl. Numer. Math., 54 (2005), pp. 167–193.
- [21] A. TOSELLI AND O. WIDLUND, *Domain decomposition methods—algorithms and theory*, vol. 34 of Springer Series in Computational Mathematics, Springer-Verlag, Berlin, 2005.
- [22] X. TU, *Three-level BDDC in two dimensions*, tech. report, New York University, 2004.
- [23] ———, *Three-level BDDC in three dimensions*, tech. report, New York University, 2005.
- [24] B. I. WOHLMUTH, *A mortar finite element method using dual spaces for the Lagrange multiplier*, SIAM J. Numer. Anal., 38 (2000), pp. 989–1012.
- [25] ———, *Discretization methods and iterative solvers based on domain decomposition*, vol. 17 of Lecture Notes in Computational Science and Engineering, Springer-Verlag, Berlin, 2001.