

FIXED – ORDER AND STRUCTURE H_∞ CONTROL WITH MODEL BASED FEEDFORWARD FOR ELASTIC WEB WINDING SYSTEMS

Dominique Knittel ⁽¹⁾, Didier Henrion ⁽²⁾, Marc Millstone ⁽³⁾, Marc Vedrines ⁽¹⁾

⁽¹⁾ *University of Strasbourg - ERT Enroulement and INSA Strasbourg - LGECO
IPST, 15 Rue du Mal. Lefebvre, 67100 Strasbourg, FRANCE.
dominique.knittel@ipst-ulp.u-strasbg.fr marc.vedrines@insa-strasbourg.fr*

⁽²⁾ *LAAS – CNRS, University of Toulouse, France and
Faculty of Electrical Engineering, Czech Technical University in Prague, Czech Republic
henrion@laas.fr*

⁽³⁾ *Courant Institute of Mathematical Sciences, New York University, New York, NY 10012
marcm@cims.nyu.edu*

Abstract: In web transport systems, the main concern is to control independently speed and tension in spite of perturbations such as radius variations and changes of setting point. This paper presents the application of nonsmooth nonconvex optimization techniques to design centralized fixed order and decentralized fixed order and fixed structure \mathcal{H}_∞ controllers with model based feedforward for web winding systems. The approach provides improved web tension and velocity regulation. First, mathematical models of fundamental elements in a web process line are presented. A state space model is developed which enables calculation of the phenomenological model feedforward signals and helps in the synthesis of \mathcal{H}_∞ controllers around the set points given by the reference signals. The \mathcal{H}_∞ control strategies with additive feedforward have been validated on a nonlinear simulator identified on a 3-motor winding test bench.

Copyright © 2007 IFAC

Keywords: winding systems, H_∞ control, fixed order control, fixed structure control, nonconvex nonsmooth optimization

1. INTRODUCTION

The systems handling web material such as textile, paper, polymer or metal are common in the manufacturing industry. Modeling and control of web handling systems have been studied for several decades. However, increasing requirement on control performance and better handling of elastic web material have led to search for more sophisticated robust control strategies. One of the objectives in such systems is to improve decoupling between web tension and speed, so that constant web tension can be maintained during process speed changes. So far, many industrial web transport systems have used decentralized PI-type controllers. However, more efficient control strategies such as LQG or \mathcal{H}_∞ are expected to provide design flexibility in the presence of various uncertainties as well as better performance. Most modern control law designs

require the construction and validation of a reasonable plant model. In this article, we use a 3-motor nonlinear simulation model resulting from modeling and identification of an experimental bench. The detailed description of the nonlinear model is given in (Koç, et al., 2002); the most important laws on which it is based will be recalled here. The model of a large scale web winding system is then deduced from the experimentally verified model. A new state space description has been constructed and presented in (Knittel, et al., 2006a). Robust control has already been applied to web handling for reduced-size systems, containing not more than 3 motors, with multivariable \mathcal{H}_∞ centralized controllers and LPV structures (Koç, et al., 2002). Nevertheless, web processing lines are generally large scale systems, i.e. with a high number of actuators and sensors, and it is not suitable to use a

centralized controller for such processes. An alternative solution is to use semi-decentralized control: the global system is split into several subsystems controlled independently by its own controller (Knittel, 2003; Benlatreche, et al., 2006). Recently, multivariable decentralized control strategies have been proposed for industrial metal transport systems (Geddes, and Postlethwaite, 1998; Grimble, and Hearn, 1999), and for elastic web with \mathcal{H}_∞ controllers (Featherstone, et al., 2000; Knittel, 2003). Decentralized control with overlapping of adjacent subsystems, as in (Siljak, 1991; Knittel, 2003; Benlatreche, et al., 2006; Pagilla, and Knittel, 2005), can be used to reduce the coupling between two consecutive subsystems. Such a control strategy has already given good results in the case of a vehicle platoon (Stankovic, et al., 2000). A number of issues related to modeling and control of continuous web processing lines were investigated in (Pagilla, et al., 2005; Pagilla, and Knittel, 2005). A major drawback of standard H_∞ design algorithms, as implemented in currently available computer-aided control system design (CACSD) software is the high order of the computed controllers. Indeed, the order of the controller is typically equal to the order of the plant plus the order of the frequency weighting functions. With current model reduction techniques, the controller order cannot always be reduced a posteriori while preserving stability and a satisfying performance. It is therefore highly relevant, especially for industrial applications, to develop design algorithms producing fixed-order (e.g. static output feedback, or multivariable PID) controllers from the outset. After more than four decades of intensive research efforts, it turns out that, deceptively, efficient software for designing fixed-order controllers is still not readily available. The underlying mathematical problem seems to be difficult since fixed-order controller design can be formulated as a typically nonsmooth (nondifferentiable) affine problem in the nonconvex cone of stable matrices. However, recent progress in nonlinear variational analysis, tailored at solving H_∞ fixed-order control problems (Burke, et al., 2003) paved the way for the development of nonsmooth optimization algorithms based on quasi-Newton (BFGS), bundling and gradient sampling. A MATLAB software called HIFOO (H-Infinity Fixed-Order Optimization) has been released in late 2005, see (Burke, et al., 2006), and uses local optimization techniques. This software has been used in this work for the reduced order and fixed structure controller calculation.

This paper presents fixed order and fixed structure \mathcal{H}_∞ controller synthesis coupled with model based feedforward control, applied to a web transport systems. Other \mathcal{H}_∞ control strategies with full order are presented in (Knittel, et al., 2006a) and with

reduced order and full structure in (Knittel, et al., 2006b). It is shown that such a strategy leads to much improved web tension and velocity regulation performance. The outline of the paper is as follows. Section 2 gives the main physical laws used to build a nonlinear model which was also identified on an experimental bench composed of three motors (Fig. 1). Linearization of the model around a fixed web tension and velocity reference values gives the state space model that is useful for modern controller synthesis. Section 3 is dedicated to centralized fixed reduced order \mathcal{H}_∞ control design with physical model based feedforward. The decentralized fixed order and fixed structure design is then described in section 4. Finally, section 5 gives conclusions of this work and indicates some future research directions.

2. PLANT MODELING

The nonlinear model (Koç, et al., 2002) of a web transport system is built from the equations describing the web tension behavior between two consecutive rolls and the velocity of each roll. This model was identified on a 3-motor experimental bench presented in Fig. 1.

A. Web Tension Calculation:

The dynamics of web tension between two rolls of web transport systems is based on three laws.

1) *Hooke's law*: the tension T of an elastic web is a function of the web strain ε :

$$T = E S \varepsilon = E S (L - L_0) / L_0 \quad (1)$$

where E is the modulus of elasticity, S the web cross section, L and L_0 are stretched and unstretched web lengths, respectively.

2) *Coulomb's law*: the study of a web tension on a roll can be considered as a problem of friction between solids (Koç, et al., 2002).

3) *Equation of Continuity*: this equation, applied to the web, yields (Koç, et al., 2002):

$$L \frac{dT_k}{dt} = E S (V_{k+1} - V_k) + T_{k-1} V_k - T_k (2V_k - V_{k+1}) \quad (2)$$

where k is the span number.



Fig. 1. Experimental setup with 3 brushless motors and 2 load cells

B. Web Velocity Calculation :

The linear velocity V_k of roll k is obtained from the torque balance (Koç, et al., 2002):

$$\frac{d}{dt} \left(J_k \frac{V_k}{R_k} \right) = R_k (T_k - T_{k-1}) + K_k U_k + C_f, \quad (3)$$

where $K_k U_k$ is the motor torque and C_f is the friction torque. In the case of unwind and rewind rolls, the inertia and radius are time dependent and can substantially vary during processing.

A large scale web handling system of any number of driven rolls can be built from the equations (2) and (3). A schematic representation of a multi-motor transport system is shown in the Appendix.

C. State Space Representation :

A scheme of a 3-motor setup with PI controllers is represented in Fig. 2. The inputs to the system are the torque control signals (u_u, u_v, u_w) of the brushless motors; the measurements are the unwinder and winder web tensions T_u and T_w and the web velocity $V = V_3$. The web velocity is imposed by the master traction motor whereas the web tensions in the different spans are controlled by the unwind and rewind motors.

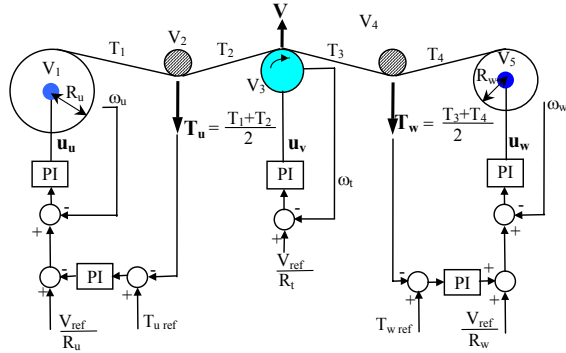

Fig 2. Distributed industrial control scheme for a winding process

The nonlinear state-space model is composed of (2) for the different web spans and (3) for the different rolls. In (Koç, et al., 2002) a global three-motor state space model is presented using a first order linearization and under the assumption that J_k/R_k is slowly varying. In this work, a more precise state space model is used by decomposing the nonlinear equations as follows (Knittel, et al., 2006a): define

$$V_i = V_0 + v_i \quad T_i = T_0 + t_i \quad U_i = U_{s_i} + u_{s_i} \quad (4)$$

where v_i, t_i, u_{s_i} are signal variations around the reference values. The three-motor system variational dynamics can be presented in the following form:

Subsystem 1 with $\underline{x}_1^T = [v_1 \quad t_1 \quad v_2 \quad t_2]$:

$$E_1 \dot{\underline{x}}_1 = A_1 \underline{x}_1 + B_1 u_{s1} + H_1 + A_{12} \underline{x}_2 \quad (5)$$

Subsystem 2 with $\underline{x}_2^T = [v_3]$:

$$E_2 \dot{\underline{x}}_2 = A_2 \underline{x}_2 + B_2 u_{s2} + H_2 + A_{21} \underline{x}_1 + A_{23} \underline{x}_3 \quad (6)$$

Subsystem 3 with $\underline{x}_3^T = [t_3 \quad v_4 \quad t_4 \quad v_5]$:

$$E_3 \dot{\underline{x}}_3 = A_3 \underline{x}_3 + B_3 u_{s3} + H_3 + A_{32} \underline{x}_2 \quad (7)$$

A detailed description of the subsystems are given in (Knittel, et al., 2006a). The constant values and the non-linear terms are included in the H_i vectors whereas the matrices A_{ij} describe the effect (coupling) of subsystem j on subsystem i .

3. REDUCED ORDER CENTRALIZED CONTROL WITH FEEDFORWARD

Robust H_∞ control is a powerful tool to synthesize multivariable controllers with interesting properties of robustness and disturbance rejection. The synthesis should be done using a linear model corresponding to the starting phase. Due to a wide variation of the roller radius during the unwinding-winding process, the dynamic behavior of the system is considerably modified with time. With quasi-static assumption on radius variations, the static gains between the control signals and web tensions appear to be proportional to the inverse of the radius (Koç, et al., 2002). We therefore multiply the control signals by the corresponding radius measurement or estimation: the controller synthesis is done using the plant which includes the radii multiplication (gain scheduling). This approach allows us to reduce web tension variations significantly despite velocity changes during processing (Koç, et al., 2002; Knittel, 2003). In this section, a centralized H_∞ controller with output weighting and model matching (Fig. 3) has been synthesized for the system composed of equations (5), (6) and (7) without the vectors H_i . Model M_o gives the desired transfer function T_{yr} . In our case, M_o is a second order transfer function.

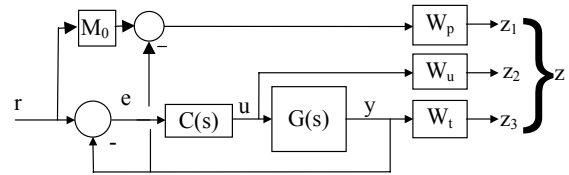

Fig. 3. S/KS/T weighting scheme with model matching for the design of H_∞ control

The weighting functions $W_p, W_u,$ and W_t appear in the closed loop transfer matrix T_{yr} which is to be minimized. The weighting function W_p has a high gain at low frequency in order to reject low frequency disturbances (Koç, et al., 2002). The weighting function W_u is used to avoid large control signals and the weighting function W_t increases the roll-off at high frequencies. To specify independently the tracking performance and robustness to perturbations, a two degree of freedom H_∞ controller can be used (Knittel, et al., 2003; Benlatreche, et al., 2006). To take into account the inherent system nonlinearities and some constant values (such as static friction in roller bearings) in the control strategy, model based feedforward signals have been added to the control signals.

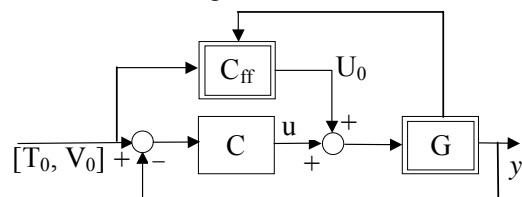

Fig. 4. Control strategy with feedforward signals

Thus, the control signal U_0 , which depends on the reference values of web tension and velocity and on the system state, is added to the H_∞ controller output u (Fig. 4). This feedforward signal is calculated online with the feedforward controller (Knittel, et al., 2006a) called C_{ff} in Fig. 4. The approach we follow to design a fixed-order linear controller ensuring closed-loop H_∞ performance is as follows:

- first, the closed-loop system must be stabilized. The closed-loop system matrix is affine in the controller state-space matrices, see e.g. relation (3) in (Burke, et al., 2006). However, this matrix is nonsymmetric, hence the stabilization problem is nonconvex when formulated in the controller parameter space. Stabilization is ensured when the so-called spectral abscissa (the largest real part of the eigenvalues) of the closed-loop system matrix is strictly negative. Hence a direct way to ensure stabilization is to minimize the spectral abscissa. It turns out that this function can be nonsmooth, or even non-Lipschitz at local optima,

- second, the H_∞ norm of the transfer function between a specified set of inputs and output must be minimized. Here too, the underlying optimization problem is typically nonconvex and nonsmooth.

In order to overcome or address nonconvexity and nonsmoothness of fixed-order H_∞ design, researchers have developed various techniques:

- convex approximations (polytopes, ellipsoids or LMI) of nonconvex stability regions, introducing an amount of conservatism which is sometimes difficult to assess;

- LMI formulations introducing lifting variables (e.g. Lyapunov matrices), which has the drawback of introducing many artificial variables (typically of the order of the square of the system dimension);

- nonconvex programming (global optimization, BMI solvers, nonsmooth optimization), mostly with a guarantee of local convergence only (since finding and certifying global optima is generally too expensive).

In this paper, we follow the latter approach. After several years of fundamental research in nonlinear variational analysis, Burke, Lewis and Overton recently designed a nonsmooth, nonconvex, hybrid optimisation algorithm implemented in a public-domain MATLAB package called HANSO (Hybrid Algorithm for Non-Smooth Optimization). The algorithm mixes in a parametrizable but user-friendly way several optimization techniques, namely quasi-Newton updating, bundling and gradient sampling (Burke, et al., 2005).

HANSO is at the core of another public-domain Matlab package called HIFOO (H_∞ Fixed Order Optimization) which is tailored at solving fixed-order controller design problems. See (Burke, et al., 2006) for a brief introduction to HIFOO 1.0, with some simple numerical examples. This software has been improved during 2006 to include fixed structure

controller calculation: HIFOO 1.5 (Millstone, 2006).

HIFOO1.5 can be downloaded at :

http://cims.nyu.edu/~marcm/software/hifoo/hifoo1_5.html

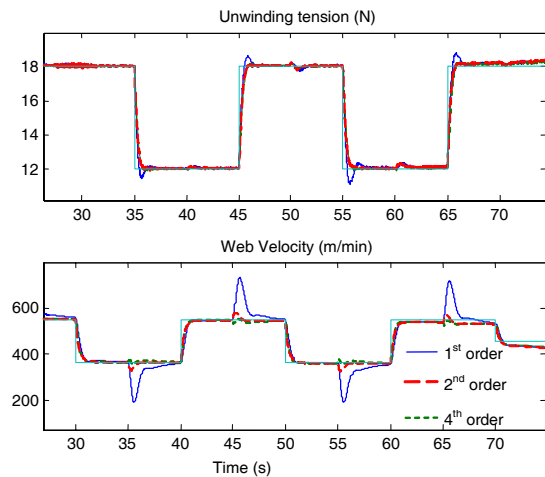

Fig. 5. Simulated web unwinding tension and web velocity for reduced order H_∞ centralized controller

Simulation results, using the non-linear simulator, are given in Fig. 5 for different orders of the centralized controller applied on the 3 motor plant. Satisfactory tracking and decoupling behavior have been obtained using the second-order controller.

4. DECENTRALIZED CONTROL WITH FEEDFORWARD

The focus of this part is to design a completely decentralized controller for web processing lines. Therefore, in industrial applications, the global system is divided into several subsystems with each subsystem containing only one actuator: one subsystem is under velocity control (master speed roll) whereas the other subsystems are under web tension control.

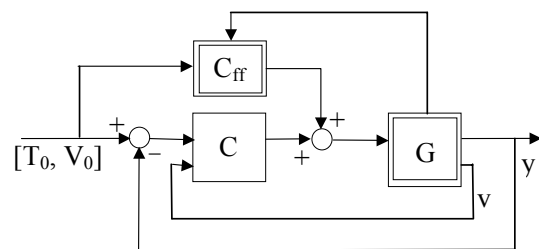

Fig. 6. Control strategy with additive measures and feedforward signals

To improve the dynamic behavior, additive measures are included in the controller synthesis (Fig. 6), similar to the PI strategy presented in Fig. 2. The control strategy for a large scale plant is given in the Appendix. In our case, the web velocity measured or estimated in each subsystem is used as the second controller input. The synthesis scheme is represented

on Fig. 7.

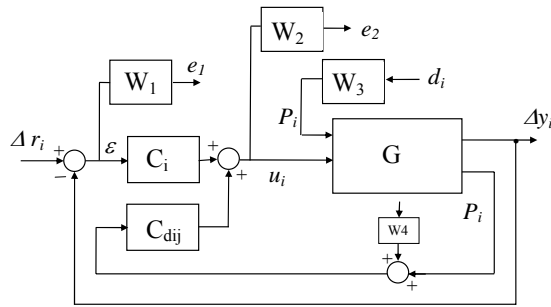

Fig. 7. H_∞ control design with additional measure

In previous studies (Knittel, et al., 2006b) each controller dedicated to each subsystem was synthesized separately. Now, the decentralized controllers are calculated in one step (for a plant with reduced number of motors) taken into account the interactions between consecutive subsystems. Simulation results are given based on a non-linear model identified on our experimental bench. Fig. 8 and Fig. 9 show respectively the web unwinding tension and web velocity simulation results (for a 3 motors-plant) for decentralized and centralized 4th order H_∞ controller. As expected, the centralized controller better improves reference tracking and more reduces the web velocity-tension coupling. The calculated decentralized controllers give satisfactory results. Nevertheless, decentralized controllers are easier to implement.

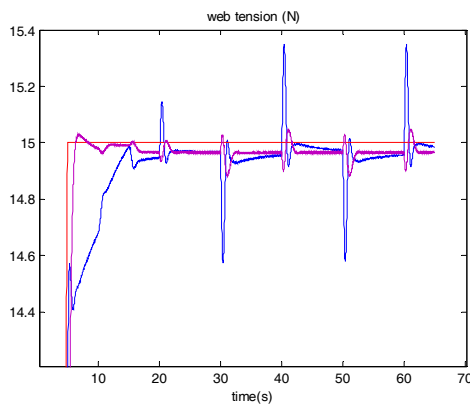

Fig. 8. Simulation results : web tension

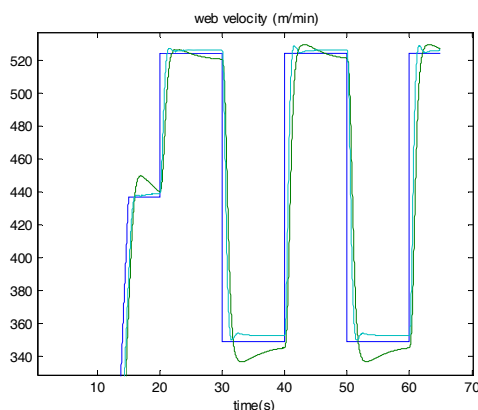

Fig. 9. Simulation results : web velocity

5. CONCLUSION

Compared to decentralized PID controllers classically used in industrial web winding systems, multivariable H_∞ controllers had already shown improved web tension and speed decoupling. Web processing lines are generally of large scale and therefore it is not suitable to use a centralized controller for such processes. A centralized fixed order and decentralized fixed order and fixed structure H_∞ controller are synthesized and validated on a nonlinear web handling simulator with reduced number of motors. Future work will deal with fixed structure controller synthesis for large scale web handling systems (i.e. with high number of motors) to improve the decoupling between consecutive subsystems. In such case, an iterative synthesis approach should be applied.

ACKNOWLEDGMENTS

This work was supported in part by the French Ministry of Research through the project “Winding and high velocity handling of flexible webs” (ERT Enroulement, contract number 01 B 0395). D. Henrion acknowledges support by the Grant Agency of the Czech Republic (project No. 102/06/0652) and the Ministry of Education of the Czech Republic (research program No. MSM6840770038). Marc Millstone acknowledges support by the U.S. National Science Foundation (grant No. DMS-0412049).

REFERENCES

- Benlatreche A., D. Knittel and E. Ostertag (2005a), State feedback controllers synthesis using BMI optimisation for large scale web handling systems, *16th IFAC World Congress*, July 4-8, Prague, Czech Republic.
- Benlatreche A., D. Knittel and E. Ostertag, (2005b), State feedback control with full or partial integral action for large scale winding systems, *40th Annual General Meeting of Industry Applications Society*, October 2-6, Hong Kong.
- Benlatreche A., D. Knittel and E. Ostertag (2006), Robust decentralized control strategies for large scale web handling systems, *IFAC J. Control Engineering Practice*, 2006.
- Burke J. V., A. S. Lewis and M. L. Overton (2003), A nonsmooth, nonconvex optimization approach to robust stabilization by static output feedback and low-order controller. *IFAC Symp. Robust Control Design, Milan, Italy*
- Burke J. V., A. S. Lewis and M. L. Overton (2005), A robust gradient sampling algorithm for nonsmooth, nonconvex optimization. *SIAM J. Optim.* 15:751-779
- Burke J. V., D. Henrion, A. S. Lewis and M. L. Overton (2006), HIFOO - a MATLAB package for fixed-order controller design and H-infinity

optimization. *IFAC Symp. Robust Control Design, Toulouse, France*

Featherstone A. P. J. G. Van Antwerp and R. Braatz (2000), *Identification and Control of Sheet and Film Processes*. Springer.

Geddes, J.E. and M., Postlethwaite (1998), Improvements in Product Quality in Tandem Cold Rolling Using Robust Multivariable Control, *IEEE Transactions on Control Systems*, vol. 6, No 2.

Grimble, M. J. and G. Hearn (1999). Advanced control for hot rolling mills, *Advances in control, Highlights of ECC'99*, Springer, pp. 135-169.

HIFOO 1.0 can be downloaded at : <http://www.cs.nyu.edu/overton/software/hifoo>

Knittel D., E. Laroche, D. Gigan and H. Koç (2003). Tension control for winding systems with two degrees of freedom H_∞ controller, *IEEE Transactions on Industry Applications* 39(1), pp. 113-120.

Knittel D. (2003), Robust control design using H_∞ methods in large scale web handling systems, *7th Int. Conf. on Web Handling, IWEB2003*, Stillwater (Oklahoma).

Knittel D., A. Arbogast, M. Vadrines and P. Pagilla (2006a), Decentralized robust control strategies with model based feedforward for elastic web winding systems, *American Control Conference*, Minnesota

Knittel D., M. Vadrines, D. Henrion and P. Pagilla (2006b), Robust H_∞ fixed order control strategies for large scale web winding systems,

IEEE Conference on Control Applications CCA/CACSD/ISIC, Germany, October 4-6

Koç, H., D. Knittel, M. de Mathelin and G. Abba (2002). Modeling and robust control of winding systems for elastic webs. *IEEE Transactions on Control Systems Technology* 10(2), pp. 197-208.

Millstone M. (2006), HIFOO 1.5 : structured control of linear systems with a non-trivial feedthrough, *Master's Thesis*. Department of Mathematics, Courant Institute of Mathematical Sciences, New York University, September.

Pagilla P. R., N. B. Siraskar and R. V. Dwivedula (2005), Decentralized adaptive control of large-scale systems with applications to web processing lines, *16th IFAC World Congress*, Prague, Czech Republic, July.

Pagilla P. R. and D. Knittel (2005), Recent advances in web longitudinal control, *8th Int. Conf. on Web Handling, IWEB2005*, Stillwater (Oklahoma).

Sakamoto T. and T. Kobayashi (2004), Decomposition and decentralized controller design of web transfer system, *IFAC Large scale systems conference*, July 26-28, Osaka, Japan

Siljak, D. D. (1991), Decentralized control of complex systems, Academic press.

Stankovic, S. S., M. J. Stanojevic and D. D. Siljak, (2000), Decentralized overlapping control of a platoon of vehicles, *IEEE Transactions on Control Systems Technology*, vol.8, N° 8, pp. 816-832, September.

Appendix : decentralized control strategy for a large scale web transport system :

